

Wireless sensors

For monitoring environmental conditions and managing single-phase electrical loads

- Temperature
- Humidity
- Light
- Plugs
- Switches

CAREL



(ENG) User manual

WARNINGS



CAREL bases the development of its products on decades of experience in HVAC, on the continuous investments in technological innovations to products, procedures and strict quality processes with in-circuit and functional testing on 100% of its products, and on the most innovative production technology available on the market. CAREL and its subsidiaries nonetheless cannot guarantee that all the aspects of the product and the software included with the product respond to the requirements of the final application, despite the product being developed according to start-of-the-art techniques.

The customer (manufacturer, developer or installer of the final equipment) accepts all liability and risk relating to the configuration of the product in order to reach the expected results in relation to the specific final installation and/or equipment.

CAREL may, based on specific agreements, acts as a consultant for the positive commissioning of the final unit/application, however in no case does it accept liability for the correct operation of the final equipment/system.

The CAREL product is a state-of-the-art product, whose operation is specified in the technical documentation supplied with the product or can be downloaded, even prior to purchase, from the website www.carel.com.

Each CAREL product, in relation to its advanced level of technology, requires setup/configuration/programming/commissioning to be able to operate in the best possible way for the specific application. The failure to complete such operations, which are required/indicated in the user manual, may cause the final product to malfunction; CAREL accepts no liability in such cases.

Only qualified personnel may install or carry out technical service on the product.

The customer must only use the product in the manner described in the documentation relating to the product.

In addition to observing any further warnings described in this manual, the following warnings must be heeded for all CAREL products:

- prevent the electronic circuits from getting wet. Rain, humidity and all types of liquids or condensate contain corrosive minerals that may damage the electronic circuits. In any case, the product should be used or stored in environments that comply with the temperature and humidity limits specified in the manual.
- do not install the device in particularly hot environments. Too high temperatures may reduce the life of electronic devices, damage them and deform or melt the plastic parts. In any case, the product should be used or stored in environments that comply with the temperature and humidity limits specified in the manual.
- do not attempt to open the device in any way other than described in the manual.
- do not drop, hit or shake the device, as the internal circuits and mechanisms may be irreparably damaged.
- do not use corrosive chemicals, solvents or aggressive detergents to clean the device.
- do not use the product for applications other than those specified in the technical manual.

All of the above suggestions likewise apply to the controllers, serial boards, programming keys or any other accessory in the CAREL product portfolio.

CAREL adopts a policy of continual development. Consequently, CAREL reserves the right to make changes and improvements to any product described in this document without prior warning.

The technical specifications shown in the manual may be changed without prior warning.

The liability of CAREL in relation to its products is specified in the CAREL general contract conditions, available on the website www.carel.com and/or by specific agreements with customers; specifically, to the extent where allowed by applicable legislation, in no case will CAREL, its employees or subsidiaries be liable for any lost earnings or sales, losses of data and information, costs of replacement goods or services, damage to things or people, downtime or any direct, indirect, incidental, actual, punitive, exemplary, special or consequential damage of any kind whatsoever, whether contractual, extra-contractual or due to negligence, or any other liabilities deriving from the installation, use or impossibility to use the product, even if CAREL or its subsidiaries are warned of the possibility of such damage.

DISPOSAL

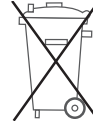

INFORMATION FOR USERS ON THE CORRECT HANDLING OF WASTE ELECTRICAL AND ELECTRONIC EQUIPMENT (WEEE)

In reference to European Union directive 2002/96/EC issued on 27 January 2003 and the related national legislation, please note that:

1. WEEE cannot be disposed of as municipal waste and such waste must be collected and disposed of separately;
2. the public or private waste collection systems defined by local legislation must be used. In addition, the equipment can be returned to the distributor at the end of its working life when buying new equipment;
3. the equipment may contain hazardous substances: the improper use or incorrect disposal of such may have negative effects on human health and on the environment;
4. the symbol (crossed-out wheeled bin) shown on the product or on the packaging and on the instruction sheet indicates that the equipment has been introduced onto the market after 13 August 2005 and that it must be disposed of separately;
5. in the event of illegal disposal of electrical and electronic waste, the penalties are specified by local waste disposal legislation.

Warranty on materials: 2 years (from the date of production, excluding consumables).

Approval: the quality and safety of CAREL S.P.A. products are guaranteed by the ISO 9001 certified design and production system.

Important warning!!!

The rTM SE system devices are incompatible with the Carel rTM system, due to an improvement made to the ZigBee™ wireless communication protocol.

Content

1. INTRODUCTION 7

1.1	Wireless monitoring devices.....	7
1.2	Codes.....	8
1.3	Terminology.....	9
1.4	Advantages of the wireless system.....	9
1.5	Type of Carel wireless network (MESH).....	10
1.6	General features of the system.....	11
1.7	Using the Router.....	11
1.8	General notes.....	11
1.9	Reference standards.....	12
1.10	Battery life.....	12
1.11	List of sensor system variables (alphabetical order).....	12

2. BP SE SENSOR (BUILT-IN PROBE) 13

2.1	Functions implemented and supervisor variables available.....	13
2.2	Sensor configuration.....	13
2.3	Sensor activation.....	14
2.4	Technical specifications.....	15
2.5	List of parameters and variables, BP SE Sensor.....	16
2.6	Installation notes.....	17
2.7	Physical dimensions.....	17
2.8	Replacing the battery in the BP SE Sensor.....	17
2.9	Application examples.....	17

3. EP SE, SA, SI SENSORS AND CI PULSE COUNTER 18

3.1	Parameters and functions.....	18
3.2	Description of the acquisition process.....	18
3.3	Device configuration.....	18
3.4	Binding procedure.....	19
3.5	Resetting the sensor (unbinding).....	19
3.6	General warnings.....	19

4. EP SENSOR (EXTERNAL PROBE) 20

4.1	Functions implemented.....	20
4.2	Parameters and functions.....	20
4.3	Technical specifications.....	20
4.4	List of parameters and variables, EP SE Sensor.....	21
4.5	EP SE Sensor installation notes.....	22
4.6	EP SE physical dimensions.....	22
4.7	EP SE electrical connections.....	22
4.8	Application example.....	22

5. SA ROOM SENSOR 23

5.1	Functions implemented and supervisor variables available.....	23
5.2	Technical specifications.....	24
5.3	List of parameters and variables, SA Sensor.....	24
5.4	Sensor installation notes.....	25
5.5	Physical dimensions.....	25
5.6	Application example.....	25

6. SI INDUSTRIAL SENSOR 26

6.1	Functions implemented and supervisor variables available.....	26
6.2	Technical specifications.....	27
6.3	List of parameters and variables, SI Sensor.....	28
6.4	SI Sensor installation notes.....	28
6.5	Physical dimensions.....	29
6.6	Application example.....	29

7. CI PULSE COUNTER 30

7.1	Functions implemented.....	30
7.2	Parameters and functions.....	30

7.3	Technical specifications.....	30
7.4	List of parameters and variables, CI Pulse Counter.....	31
7.5	CI Pulse Counter installation notes.....	32
7.6	CI Pulse Counter physical dimensions.....	32
7.7	CI Pulse Counter electrical connections.....	32
7.8	Connection example.....	32

8. AP ACCESS POINT 33

8.1	Main functions.....	33
8.2	Parameters and functions.....	33
8.3	Configuration.....	33
8.4	Setting the address.....	33
8.5	Binding procedure.....	34
8.6	Resetting the device.....	34
8.7	Serial communication parameters.....	34
8.8	Table of LED status.....	35
8.9	Technical specifications.....	35
8.10	List of Access Point system variables (alphabetical order).....	36
8.11	List of parameters and variables, Access Point versione Modbus RTU®.....	37
8.12	Installation notes.....	37
8.13	Electrical connections and physical dimensions.....	38

9. RO ROUTER 39

9.1	Parameters and functions.....	39
9.2	Binding the Router to the Access Point.....	39
9.3	Resetting the device.....	40
9.4	Table of LED status.....	40

10. ROUTERS WITH OTHER INTEGRATED FUNCTIONS 41

10.1	EP1 Router-Sensor.....	41
10.2	RB Router-Bridge.....	41
10.3	RA Router-Actuator.....	42
10.4	Functions implemented.....	42
10.5	RC Router-Pulse Counter.....	42
10.6	Technical specifications.....	43
10.7	List of Router system variables (alphabetical order).....	43
10.8	List of Router parameters.....	44
10.9	List of RA Router-Actuator parameters.....	44
10.10	Installation notes.....	44
10.11	General warnings.....	46

11. GENERAL NOTES 47

11.1	Notes for correct installation.....	47
------	-------------------------------------	----

12. RTM SE HANDHELD 48

12.1	General Features.....	48
12.2	Operating modes.....	48
12.3	Main menu.....	48
12.4	Scan Energy.....	48
12.5	Scan Networks.....	49

12.6	Scan Connection	49
12.7	Unbinding.....	49
12.8	Ping test.....	49
12.9	Network commands.....	49
12.10	“View Mode” menu.....	50
12.11	“Open Network” menu.....	50
12.12	“Reset One” menu	50
12.13	Password entry menu	50
12.14	“Set Passw” Menu – Set Access Point password	51
12.15	Sensors menu	51
12.16	List of Sensors	51
12.17	Set Sensor address.....	52
12.18	Unbind Sensor	53
12.19	Start screen.....	54
12.20	ZigBee™ handheld signal meter shutdown	54
12.21	Notes on operation	54
12.22	ZigBee™ handheld signal meter electrical specifications.....	54
12.23	Physical dimensions	54

13. ROUTER-SNIFFER 55

13.1	Router-Sniffer	55
13.2	Technical specifications:.....	55
13.3	Layout	55
13.4	LED meanings.....	55

14. Z-CONFIG PROGRAM 56

14.5	Layout examples	61
------	-----------------------	----

15. DIPSWITCH-ID CROSS-REFERENCE TABLE FOR SENSORS 63

15.1	Dipswitch-ID cross-reference table for sensors.....	63
------	---	----

1. INTRODUCTION

1.1 Wireless monitoring devices energy consumption measurement

For the retrofit of food refrigeration and room cooling systems, energy consumption measurement and I/O management via supervisor, CAREL proposes the rTM SE wireless system (Remote Temperature Monitoring). This solution guarantees the maximum in terms of:

- Flexibility;
- Functions;
- Reliability;
- Easy operation
- Reduced installation costs;
- Easy commissioning/service;
- Integration with the most common BMS (Building Management Systems);

This solution ensures considerable savings in terms of installation costs (eliminating the cost of wiring), offering flexibility in the layout of supermarkets and allowing faster retrofit installation. Ideal for all installations where electrical wires cannot be laid, i.e. properties that do not have raised floors or false ceilings.

The retrofit of existing systems is required for compliance with HACCP standards, for monitoring the systems via remote connections, for recording events and analysing them for scheduled maintenance.

The CAREL rTM SE system can be used in all industrial and trade businesses that require the prevention of risks relating to the safety and storage of food for human consumption, in accordance with the HACCP standards; moreover, it offers the possibility to manage flexible spaces very simply, thus reorganising the layout of showcases in a supermarket without having an impact on the wired network (communication and power supply);

The system is a network of wireless sensors fitted inside the showcases, easy to configure and install, connected to a Carel supervisor (PlantVisorPRO or PlantWatchPRO) for recording the temperature, events and alarm notifications. The data measured and the alarms signalled are saved and can be accessed at any time, in compliance with EN 12830.

The system can be easily installed on all types of refrigeration unit (showcases or cold rooms), is independent of the controller installed on the unit and requires no additional wiring because the devices are wireless and battery powered, meaning significant cost savings.

The sensors require no electrical connections as they use a long life battery (typically 5 to 8 years, depending on the transmission frequency set), a wireless connection with ZigBee™ technology (mesh) at a transmission frequency of 2.4 GHz authorised for operation in all countries around the world, and are ready for connection to the most common BMS systems using Modbus® protocol. The sensors monitor the inputs (temperature, humidity, light and digital input status) and send the data wirelessly to the Access Point or Router. Communication between sensors and the Access Point is two way. The sensors, as well as sending the change in the status of the variables, can also receive data.

Moreover, a mains powered model has been designed for use in all applications that require frequent communication (e.g. monitoring floating suction pressure).

In ambient monitoring applications, the temperature, humidity and light intensity can all be recorded by simply installing battery powered sensors in the desired location. The sensors cover a wide range of uses in refrigeration, air-conditioning and humidification applications.

Many applications are also available for remote I/O management from supervisors, as the module manages generic I/Os and saves on the cost of laying cables, without the need for separate power and signal cables.

The wireless devices send the temperature and alarm data wirelessly to the Router and Access Point, which relay the information to the supervisory system

The CAREL rTM SE system consists of the following components:

- Battery powered devices:
 - Temperature sensor from fitted inside the showcase, **version BP SE** (Built-in Probe).
 - Sensor with two external NTC probes and two digital inputs, **version EP SE** (External Probe) for showcases and cold rooms.
 - Room temperature and humidity sensor for installation in residential environments, **version SA**.
 - Temperature, humidity and light sensor, SI industrial version.
 - Pulse counter to be used with the energy meter module configured for pulse counters, **version CI**.
 - Devices for measuring single-phase electricity consumption and managing electrical loads with scheduled activation.
- Access Point. Wireless receiver that acquires data from the various sensors in the ZigBee™ network, making such data available to the supervisor via Modbus® RTU over RS485. Up to 30 sensors can be directly associated with each Access Point, or a maximum of 60 if one or more Routers are used. The supervisor (PlantVisorPRO or PlantWatchPRO) can thus see all the variables in the rTM SE system;
- Router. To be used when the distance between the Sensors and the Router exceeds 30 m (relays the wireless signals so as to cover greater distances between the Access Point and sensors), or if there are more than 30 Sensors in the network. There can be a maximum of 60 Routers in the wireless network, 48 of which are visible to the supervisor. The Access Point automatically assigns a serial address in the order in which these are "bound", starting from 200 up to 247. Five versions of Router are available, which also include other functions:
 - Router powered at 230 Vac mains voltage, version RO;
 - Router Bridge powered at 12-24 Vac, version RB. Integrates the function to extend the RS485 network;
 - Router Sensor powered at 12-24 Vac, version EP1. Integrates the functions of the battery powered EP SE Sensor);
 - Router-Actuator powered at 12-24 Vac, version RA. Integrates the functions of I/O module or local thermostat;
 - Router-Pulse Counter powered at 12-24 Vac, version RC. Integrates the same functions as the CI battery powered pulse counter;
- Modbus® supervisor system: The rTM SE system is designed to be used together with Carel PlantVisor PRO or PlantWatch PRO supervisors

Wireless transmission between the various devices uses standard ZigBee™ communication protocol and encryption technology with a Carel private key. This is an advanced system that has achieved an excellent level of security in data exchange for wireless communication and is used in many applications. The CAREL solution uses mesh technology between Access Points and Routers, ensuring more reliable communication and delivery of the data sent by the sensor.

Note: ZigBee™ wireless connection without interoperability.

rTM SE handheld: network analyser used to check the ZigBee™ wireless signal level and to open/close the wireless network when binding the devices (sensors and Routers), including the possibility to set the BP Sensor address and reset the Router and Access Point. Useful during installation;

1.2 Codes

Code	Model	Features	Power supply
WS01U01M00	BP SE sensor	Temp. for showcases	Battery
WS01U01M01	BP SE sensor (Multiple-pack 20pz)	Temp. for showcases	Battery
WS01W02M00	EP SE sensor	Temp. for cold rooms or showcases	Battery
WS01G01M00	SA sensor	Room temp./humid.	Battery
WS01F01M00	SI sensor	Temp./humid./lux for industrial use	Battery
WS01AB2M20	Access Point	ZigBee™ – RS485 Modbus® wireless gateway	12/24 Vac/dc
WS01RC1M20	Router	ZigBee™ wireless repeater	230 Vac
WS01VB2M10	Router-sensor EP1	Repeater + Temp. sensor	12/24 Vac/dc
WS01RB2M20	Router-Bridge	RS485 Modbus® repeater + Bridge	12/24 Vac/dc
WS01H02M20	Router-Actuator	Repeater + I/O module or thermostat	12 Vac/dc
WS01E02M00	Pulse counter	Pulse counter for energy modules	Battery
WS01N02M20	Router- Pulse counter	Repeater + Pulse counter for energy modules	12/24 Vac/dc
WS01C010I0	rTM Plug - Italian	Single-phase energy meter (10 A relay max 250 Vac)	85-250 Vac
WS01C010G0	rTM Plug - British	Single-phase energy meter (10 A relay max 250 Vac)	85-250 Vac
WS01C010F0	rTM Plug - French	Single-phase energy meter (10 A relay max 250 Vac)	85-250 Vac
WS01C010E0	rTM Plug - German (European Schuko)	Single-phase energy meter (10 A relay max 250 Vac)	85-250 Vac
WS01C010X0	rTM Switch - Universal	Single-phase energy meter (10 A relay max 250 Vac)	85-250 Vac

Tab. 1.a



Sensore BP SE



Sensore EP SE



Sensore SA



Sensore SI



Conta Impulsi CI



Access point



Router RO



Router- sensore EP1



Router-Bridge RB



Router-Attuatore RA



Router- contaimpulsi RC



rTM Plug Francese



rTM Plug Inglese



rTM Plug Italiano



rTM Plug Tedesco



Switch universale

1.3 Terminology

Wireless

Wireless means “without wires”, in contrast to the term wired.

Wireless network

Communications system (series of devices, appliances, methods and protocols) for the transmission of information via radio, typically radio-frequency technology used instead of wired connections, making the systems particularly flexible.

ZigBee™

ZigBee™ is a set of specifications based on the IEEE-802.15.4 standard for the creation of Wireless Personal Area Networks (WPAN). Comparable in some ways to Bluetooth, it stands out for its very low power consumption and the reduced cost of implementation, despite having a maximum data transfer speed of 250 kbit/s. ZigBee™ devices, with compact dimensions and low costs, are designed to work in dedicated self-organised networks (Mesh networks) and are used in many fields.

1.4 Advantages of the wireless system

Advantages of a wireless network over a wired network

- Mobility of sensors;
- Easy to install and connect the devices;
- Coverage even where obstacles are present;
- Flexibility in the event of structural modifications;
- Reduction in wiring costs;
- Robustness.

The advantages of wireless networks can overcome some of the intrinsic limits in wired systems. Typical network infrastructure features a wired backbone with wireless access.

Advantages of ZigBee™

- Standard technology;
- Reduced costs;
- Can be used globally;
- Reliable;
- Supports a large number of nodes;
- Easy configuration;
- Long battery life;
- Secure data transmission.

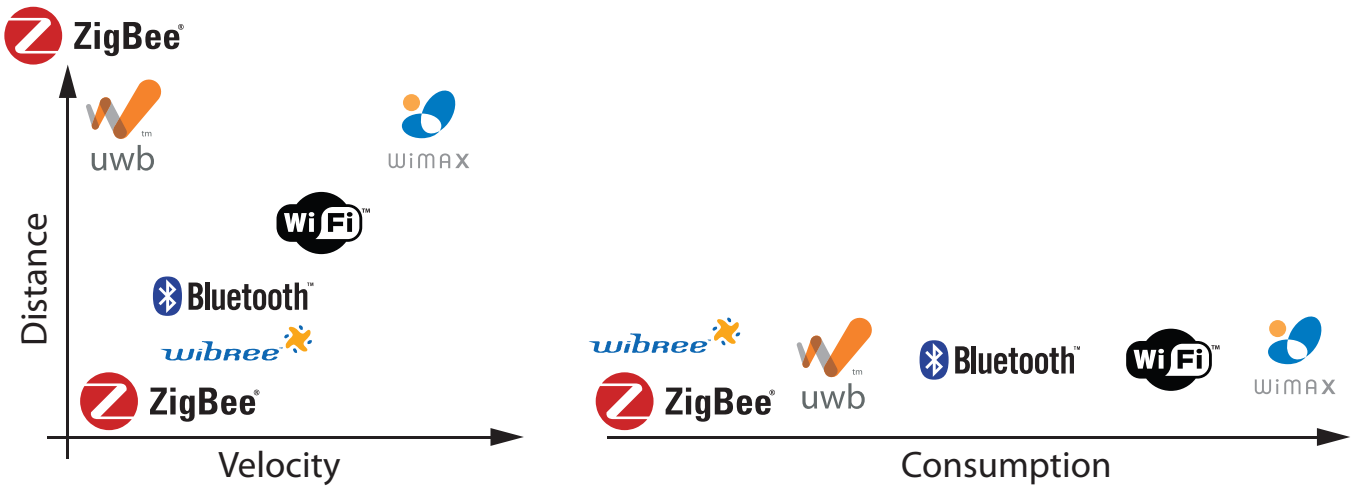

Fig. 1.a

All brands and names shown in the diagram are registered trademarks and the property of their respective owners.

Advantages of working at 2.4 GHz

Band of frequencies	No. of channels	Data parameters			Use
		Symbol rate	Bit rate	Mapping	
868-868.6 MHz	1	20Kbit/s	20 Kbaud	Binary	Europe
902-928 MHz	10	40Kbit/s	40 Kbaud	Binary	North America
2.4-2.4835 GHz	16	250Kbit/s	62.5 Kbaud	16-ary orthogonal	Worldwide

The band centred around 2.45 GHz (used in the wireless sensor system for refrigeration) is the only one that can be used all over the world, without needing to apply for special licenses. In addition, the ISM band (Industrial, Scientific and Medical) exploits the full potential of the standard, that is, can use 16 transmission channels with a bit rate of 250 kbit/s.

Types of nodes

ZigBee™ Access Point - Co-ordinator and Gateway;

- Must be available and on in every network
- Coordinates the creation of the network;

ZigBee™ Router;

- Participates in the delivery of the messages, and must always be on;
- Available in Router-Bridge version for extending a wired local network (for a list of approved controllers, see chapter on the features of the Router), and EP1 Router-Sensor version.

ZigBee™ End-Device (sensors);

- Node with limited wireless functions;
- Low power consumption;
- Low cost;

For data communication with the Access Point, the end device uses a “parent” for effective wireless transmission; this may be a Router or the Access Point itself.

1.5 Type of Carel wireless network (MESH)

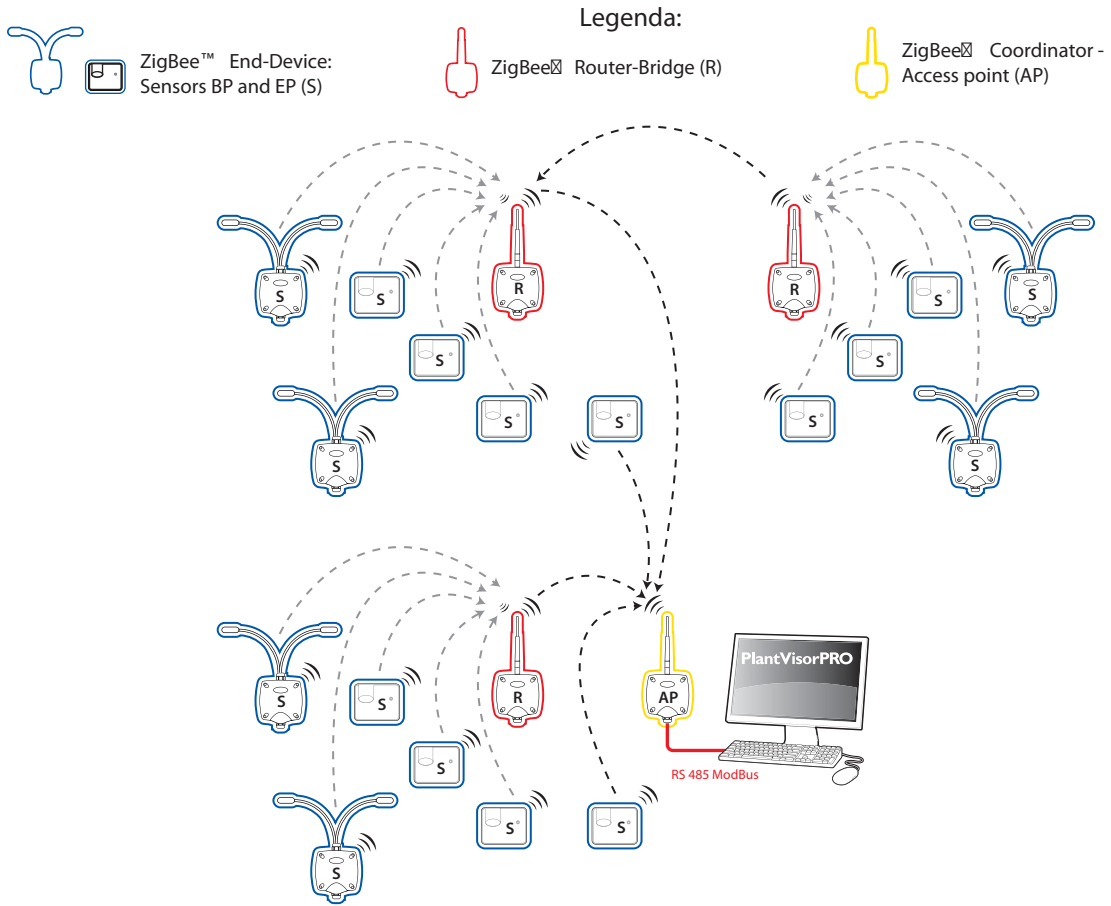

Fig. 1.b

Example of a Mesh network

The MESH layout, used in the wireless sensor system for refrigeration between coordinator nodes (access points) and router-bridge devices, ensures a high tolerance to faults, as if one sensor loses wireless communication, the radio signal still manages to find an alternative route to reach the destination.

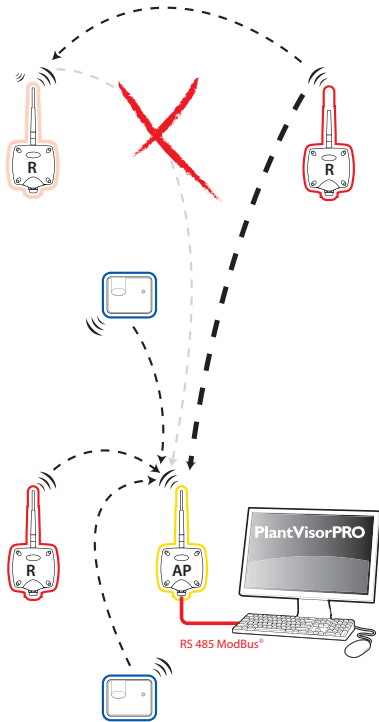

Fig. 1.c

1.6 General features of the system

Maximum distance between Access Point/Router and Sensors in open field (outdoors): 100 m.

Maximum distance between Access Point/Router and Sensors with field of sight (indoors): around 30 m (inside rooms and built-up areas).

Transmission frequency: selectable from 2405 to 2480 MHz.

Number of channels available: 16.

Transmission power:

• Access Point	0 dBm
• Router 230Vac	+10 dBm
• Router Bridge	0 dBm
• EP1 Router-Sensor	+10 dBm
• RA Router-Actuator	+3 dBm
• Router-Pulse Counter	+10 dBm
• BP SE Sensor	+3 dBm
• EP SE Sensor	+3 dBm
• SA Room Sensor	+3 dBm
• SI Industrial Sensor	+3 dBm
• CI Pulse Counter	+3 dBm

Wireless protocol: ZigBee™ without interoperability.
Standard: 802.15.4.

Reception sensitivity:

• Access Point	-92 dBm
• Router SE 230Vac	-97 dBm
• Router Bridge	-92 dBm
• Router EP probe1	-97 dBm
• RA Router-Actuator	-95 dBm
• Router-Pulse Counter	-97 dBm
• BP SE Sensor	-95 dBm
• EP SE Sensor	-95 dBm
• SA Room Sensor	-95 dBm
• SI Industrial Sensor	-95 dBm
• CI Pulse Counter	-95 dBm

For battery powered devices:

- Maximum current for battery powered devices only: 35 mA, in transmission.
- Current in standby: 1 µA.

Maximum HOP levels: 7 (hops).

Maximum number of wireless network devices:

- 30 for each Access Point (with 1 Router up to 60 units);
- 16 Routers directly connectable to the Access Point up to a maximum of 60 devices on the same network;
- 16 Router directly connectable to each Router up to a maximum of 60 devices on the same network;

Maximum number devices on Modbus® RS485 network:

- 7 Access Point;
- 111 Sensors;
- 60 Routers, max 48 of which monitored by the supervisor;
- On Modbus network in combination with other devices up to max 247 units.

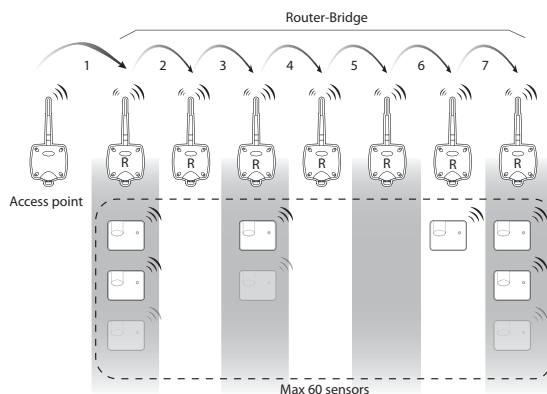

Fig. 1.d

1.7 Using the Router

When does the Router need to be installed?

The Router is required whenever a direct connection is not possible between the Access Point and the Sensor; this may occur when:

- The distance between Access Point and Sensor is greater than 30 m MAX with visibility between the instruments.
- There is no visibility between the Access Point and the Sensor, and/or there is shielding infrastructure that reduces the wireless communication distance.
- In addition, the Router is required if the number of Sensors managed exceeds 30 devices.

In addition, this is used to improve the reliability of the wireless connection, the Router network can in fact find an alternative path if one of the direct connections between the sensors and the access point fails.

Recommended:

Up to 15 sensors 1 Router;
from 16 to 30 sensors 2 Routers;
from 31 to 45 sensors 3 Routers;
from 46 to 60 sensors 4 Routers.

1.8 General notes

The radio range of the devices is around a hundred metres in an open field, that is, without any obstacles.

In a closed field the range varies significantly based on the type of environment and the surrounding objects (shelves, furniture, metal walls etc.).

Thick partition walls or reinforced ceilings and floors may represent impassable obstacles.

The ideal position of the devices, especially the routers, often cannot be defined theoretically but must be found by trial and error in the actual installation.

Serial address assignment is valid for all devices

Make sure not to assign the same serial address ID to two devices in the same wireless network.

1.9 Reference standards

The Carel wireless sensors have been tested in accordance with the following standards:

INDUSTRIAL ENVIRONMENT

EN61000-6-4, EN61000-3-2, EN61000-3-3, EN61000-6-2

ETSI EN 301 489-17 V1.2.1, ETSI EN 301 489-1 V1.4.1

RES., COMM. AND LIGHT IND. ENVIRONMENT

EN61000-6-3; EN61000-3-2, EN61000-3-3; EN61000-6-1

Compliant with EN 13485 (Instruments for measuring the temperature of foodstuffs)

1.10 Battery life

Transmission time in min.	Sensor battery life in years
1	3
5	5
10	8
15	8

Tab. 1.b

The battery life is purely indicative and depends on the cycle transmission time set and the quality of the wireless connection. If the device does not communicate correctly with the Access Point (distance or interference problems) battery life will be reduced due to the continuous attempts to restore connection to the Access Point/Router.

1.11 List of sensor system variables (alphabetical order)

Name	Description
ADD_HIGH_T_DELAY	If when a high temperature is measured the "door open" or "defrost in progress" signals are present, the device delays the alarm by the value set for ADD_HIGH_T_DELAY (HR12).
ALM_BATTERY	Provides the flat battery signal (1 if < 2800 mV).
ALM_GENERAL	Provides a general sensor fault signal.
ALM_LONG_DEFROST	Provides the alarm status for the Defrost input (1=Alarm);
ALM_PROBE_1	Temperature measurement alarm on probe 1. This may be caused by a value outside of the maximum range or by the probe not connected correctly (open or short-circuited).
ALM_PROBE_2	Temperature measurement alarm on probe 2. This may be caused by a value outside of the maximum range or by the probe not connected correctly (open or short-circuited).
AP_RX_RADIO_LEV	Wireless signal level received from the Access Point for the sensor (see note 1).
AUTO_DELAY	Defines a delay time for the evaluation of the type of showcase when auto-configuration mode is enabled.
AVERAGE_PARAM	Weight for calculating the average, as per the formula with weight M.
AVG_TEMPERATURE	Temperature value calculated as the weighted average (in tenths of a degree °C).
BATTERY_CHARGE	Defines the residual charge, counting power consumption corresponding to the operations effectively carried out. This can be used, together with the BATTERY_LEVEL value, for a more complete evaluation of battery charge status. Full charge mAh.
BATTERY_LEVEL	Battery voltage value (mV). The rated value is 3600 mV, below 2800 mV the battery is discharged.
CMD_PASSW_1	Only used by configuration systems.
CNT_REJOIN	Wireless network parameter for internal use
DEFROST_ALM_DELAY	Delay time (wait) in minutes before Defrost alarm signal
DEFROST_POL	Logical state of the defrost input based on the electrical state of the contact (open or closed).
DOOR_POL	Logical state of the door input according to the electrical state of the contact (open or closed).
EN_AUTO_CONF	Enable automatic configuration mode (1= enabled).
EN_CMD_PW	Only used by configuration systems.
EN_DI_DEFROST	Enable/disable defrost digital input.
EN_DI_DOOR	Enable/disable door digital input.
EN_HI_TEMP_ALM	Enable the high temperature alarm signal (if=1), otherwise the alarm is not measured/signalled. Used for both probes 1 and 2.
EN_SCAFFALE	Selects the medium temperature shelf display case (1=shelf)
FW_VERSION	FW revision
HI_TEMP_ALM_1	Provides the status of the high temperature alarm for probe 1
HI_TEMP_ALM_2	Provides the status of the high temperature alarm for probe 2
HI_TEMP_TRESHOLD	High temperature signal thresholds (in tenths of a degree °C)
HI_TEMP_TRE-SHOLD_1	High temperature signal threshold for probe 1. Can be set in tenths of a degree centigrade
HI_TEMP_TRE-SHOLD_2	High temperature signal threshold for probe 2. Can be set in tenths of a degree centigrade
HIGH_TEMP_DELAY	Delay (waiting) time in minutes before the high temperature alarm is actually signalled. Used for both probes 1 and 2
ID_SER_ADDR	Sensor serial address, set using the rTM SE handheld or by switch. Used as the sensor identifier
IN_1_STATUS	Status of digital input 1
IN_2_STATUS	Status of digital input 2
LAST_RX_DELAY	Wireless network parameter for internal use
LO_TEMP_ALM	Provides the status of the low temperature alarm
LO_TEMP_ALM_1	Provides the status of the low temperature alarm for probe 1
LO_TEMP_ALM_2	Provides the status of the low temperature alarm for probe 2
LO_TEMP_TRESHOLD	Low temperature signal threshold (in tenths of a degree °C). Signal without delays.
LO_TEMP_TRE-SHOLD_1	Low temperature signal threshold for probe 1. Can be set in tenths of °C. Signal without delays
LO_TEMP_TRE-SHOLD_2	Low temperature signal threshold for probe 2. Can be set in tenths of °C. Signal without delays
MAC_ADDR_0	Unique 32 bit unit identifier, LSB. Used to uniquely identify each sensor
MAC_ADDR_1	Unique 32 bit unit identifier, MSB. Used to uniquely identify each sensor
MACHINE_CODE	Peripheral identifier for the supervisor
MIN_RSSI_LEVEL	Wireless network parameter for internal use
MIRROR_IS	Wireless network parameter for internal use
MODE_AUTO_TRESH	Defines a threshold in °C below which the procedure for the automatic recognition of the type of showcase is activated.

MODE_PARAM	Defines the values to be assigned or auto-assigned for the identification of the effective operating mode. For each of the four modes, the associated parameters can be set separately, and are loaded when the mode is activated
NETWORK_ID	Wireless network parameter for internal use
OFFS_TEMP	Temperature measurement offset, within a maximum of ±9.9 °C.
OFFS_TEMP_1	Calibration offset for probe 1, within a max of ±9.9 C;
OFFS_TEMP_2	Calibration offset for probe 2, within a max of ±9.9 C;
RX_MESSAGE_CNT	Wireless network parameter for internal use
RX_MSG_LEVEL	Wireless signal level received for the sensor in dBm+100 (see note 1).
TEMPERATURE	Instant temperature value (in tenths of a degree °C).
TEMPERATURE_1	Provides the temperature values measured by probe 1. The temperature reading is in the range from -50°C to +90°C;
TEMPERATURE_2	Provides the temperature values measured by probe 2. The temperature reading is in the range from -50°C to +90°C;
TIME_STAMP	Value expressed in hours:minutes associated with the last wireless data transmissions received. This can be used to synchronise the measurements from different units with the same clock. Variable added by the Access Point for each sensor.
TRANSM_CYCLE	Defines the wireless data transmission time to the Access Point. The value is set in seconds, but must correspond (rounded off) to a multiple of 60, thus in minutes (see note 2).
TX_MESSAGE_CNT	Wireless network parameter for internal use
TX_POWER	Wireless network parameter for internal use
DEF_TIME	Defrost duration, expressed (minutes)
DEF_INTER	Defrost interval (h)
Energy consumed Wh	Electricity consumption measured in Wh
Active power W	Active power consumption in Watts
RELE_STATUS	Relay output status (on or off)

Tab. 1.c

Note:

- The two values provide an indication of the wireless signal levels seen from the sensor and the Access Point. The minimum value must be greater than 8, for medium reception from 15 to 30, and excellent for values greater than 30.
- To maximise battery life, the number of transmissions should be limited to the minimum possible.

2. BP SE SENSOR (BUILT-IN PROBE)



Fig. 2.a

The BP SE Sensor is designed to be positioned directly inside the showcases, fitted using its own fastening bracket. The rear features metal shielding that, combined with the thermal insulation inside the shell, prevents the formation of frost at the rear of the sensor, and consequently better thermal insulation from the wall.

2.1 Functions implemented and supervisor variables available

- Instant temperature measurement performed every minute.
- Measurement filtering with weighted average based on parameter setting for product temperature simulation.
- Data transmission at settable intervals, in minutes (the parameter affects battery life).
- Monitoring of temperature thresholds for high temperature (HACCP) or low temperature (product freezing) alarm signals.
- Automatic mode with preset parameters according to the showcase/display case (normal, low temperature or open shelf).
- Local mode for Clean showcase status signal. Activating the Clean button disables the high temperature alarms.
- TimeStamp for recording the instant measurement, expressed in hh:mm.
- Battery level in mV and residual charge in mAh.
- Wireless signal level in dBm +100 (less than 8=low, 15-30=medium, higher than 30=excellent);
- Temperature alarm status related to the high and low thresholds.

2.2 Sensor configuration

The sensor is supplied with the address ID set to 127 and cannot be used with the default ID; the range of available addresses is from 16 to 126. To assign the ID use the rTM SE handheld accessory. For details on the address assignment procedure see the instructions in the chapter on the rTM SE handheld further on.

In emergency situations a new ID can be assigned (limited to the range from 16 to 99) using a magnet (e.g. magnetic screwdriver Carel code 0000000722), as follows:

1. Position the magnet on SW1, holding it in position when the green LED comes on;
2. The following will be shown in sequence:
 - Green LED ON for 2 to 3s then OFF for 3 to 4s;
 - Orange LED ON for 3 to 4s;
 - Remove the magnet when the LED switches off;
 - After a few moments the LED comes on yellow for 1s. This indicates that programming procedure is active (if no actions are performed, programming mode ends after 4/5 s, indicated by a double yellow flash, leaving all the settings unchanged);
3. Move the Clean switch SW2 up and down a number of times equal to the tens of the serial address being set (e.g. 10, once – 50, five times). Each time switch SW2 is moved up the red LED comes on for 1 s, (confirming stimulation);
4. Subsequently use the magnet to stimulate switch SW1 a number of times equal to the units (e.g. 1, once – 5, five times). Each time the magnet moves over the switch the green LED comes on for 1 s (confirming stimulation). The order is not important (tens or units first);
5. After 4/5 s the sensor exits the procedure, with the yellow LED flashing twice (indicating the end of serial address setting mode);
6. Subsequently the sensor shows the serial address using a sequence of flashes repeated cyclically three times. To read the codes, see the chapter "Display sensor serial ID" further on.
7. Moving switch SW2 up interrupts the cycle;

The sensor address has been set and it's ready to be bound to an Access Point. The procedure can be performed before or after binding to the Access Point.

Make sure not to assign duplicate serial addresses, also considering other devices in the network. For further information and explanations on the procedure, see the rTM SE system installation guide.

Binding procedure

Binding is a special procedure used to associate the sensors with the Access Point. Once completed, the sensors will send the temperature data measure wirelessly only to the Access Point defined as its parent. Following this, the Access Point will forward the data to the Modbus® RTU RS485 serial network. The binding procedure requires the activation of the Access Point wireless network and activation of the configuration switch SW1 using a magnet (see the figure), done by passing the special magnet over magnetic switch SW1 for a few seconds. The LEDs will come on in sequence: green (1s), yellow (4 to 5s), green (6 to 10s). If at the end of the sequence the red LED flashes briefly (1 to 2s), binding with the Access Point has failed. If the operation is successful, successively activating switch SW1 will start manual data transmission, signalled by the green LED flashing quickly twice.

If the automatic or manual data transmission fails, the red LED will flash briefly after the green LED comes on.

After this operation the sensor will start sending data on the temperature measured, in the time interval set by parameter. Check that the LED comes on for a few seconds at regular intervals, based on the transmission time set for parameter (HR_01 TRANS_CYCLE). When the operation has ended close the wireless network on the Access Point. The wireless network can be opened and closed using the rTM SE handheld accessory.

Display sensor serial ID

To check the sensor serial address, proceed as follows:

- Move switch SW2 (CLEAN) up, stimulate SW1;
- The LED starts flashing in sequence. Count the number of the flashes to calculate the hundreds (Yellow), tens (Green) and units (Red). Removing the magnet or lowering the button exits the display probe serial address procedure.
- Move switch SW2 back down.

Yellow	Red	Green
X 100	X 10	X 1
Hundreds	Tens	Units

Tab. 2.a

Example

0 yellow flashes	5 red flashes	7 green flashes
0	5	7

Sensor address ID=57

Tab. 2.b

Resetting the sensor (maintaining the serial address)

The reset procedure is required when the sensor needs to be moved and associated with another wireless network (different Access Point). This operation may be required to reconfigure the sensor in a different wireless network. The value of the serial address remains the same, and after a new binding operation the sensor is reactivated in the wireless network. To reset the sensor, proceed as follows:

1. Place the magnet near magnetic switch SW1 (the green LED will come on);
2. Hold the magnet in place until the green LED goes off and the yellow LED comes on (after approx. 6 to 10 sec.);
3. When the yellow LED comes on, move the magnet immediately away from the sensor and check that the LED flashes quickly before going off (RESET COMPLETE).

To check that the sensor has been reset, proceed as follows:

1. Make sure the Access Point wireless network is closed (L1 flashing slowly 1s);
2. Stimulate switch SW1 on the sensor with the magnet;
3. Check that LEDs come on in the following sequence:
 - green LED (1 s);
 - yellow LED (4 to 5 s);
 - green LED (15 s);
 - red LED (1 s);

Make sure that there are no sensors with the same serial address in the new network. If this is the case, assign a new serial address.

RESET sensor and assign default serial address (=127)

- To restore the sensor serial address to the default value, proceed as follows:
1. Place the magnet near magnetic switch SW1, the green LED will come on.
 2. Hold the magnet in position until the green LED goes off and the yellow LED comes on (after approx. 6 to 10 s);
 3. Immediately remove the magnet from the sensor and at the same time move the CLEAN switch (SW2) up, making sure the yellow LED flashes a few times.
 4. Move the CLEAN switch to the OFF position and make sure the yellow LED completes a rapid sequence of flashes (RESET COMPLETE);

Otherwise repeat the procedure.

- To check that the sensor has effectively been reset, proceed as follows:
1. Make sure the Access Point wireless network is closed (L1 flashing slowly 1 s);
 2. Stimulate the switch SW1 with the magnet;
 3. Check that LEDs come on in the following sequence:
 - green LED (1 sec.);
 - yellow LED (4 to 5 sec.);
 - green LED (15 sec.);
 - red LED (1 sec.);

Completing the reset procedure and assigning the default serial address returns the sensors to the same status as a new device. To assign a new address, repeat the serial address assignment procedure.

- Note:**
1. The sensor can only be reset if it has already been bound to an Access Point.
 2. Note that, after resetting the sensor, the number of devices set for the Access Point remains unchanged. Realignment will occur after a maximum of around 2 hours.

Meaning of the switches and LED signals

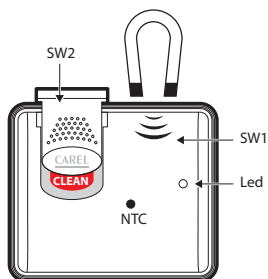

Fig. 2.b

- Key:**
- SW1 Internal magnetic configuration switch (above the LED, labelled). Can be activated by external magnet
 - SW2 Magnetic CLEAN switch (open = CLEAN MODE)
 - LED Two-colour red/green (yellow if both are on)
 - NTC Located inside the case in thermal contact directly with the front wall

The following table describes how the LEDs flash whenever SW1 or SW2 are stimulated or when data is transmitted.

Action	LED sequence (times in s.)	Meaning of the signal
Stimulating SW1 / data transmission	Green flashing (approx. 1s)	Communication with Access Point occurred correctly
Stimulating SW1 / data transmission	Green flashing (approx. 1s) → red ON (approx. 0.5s)	Communication with Access Point NOT successful
Stimulating SW1 / data transmission	Green flashing (approx. 1s) → OFF (approx. 1s) → red ON (approx. 0.5s)	Communication with Access Point NOT successful
Stimulating SW1	Green ON (approx. 1s) → yellow ON (4.5s) → green ON (approx. 15s) → red ON (approx. 1s)	BP SE Sensor in Reset status
Binding with Access Point failed		
Stimulating SW1	Green ON (approx. 1s) → yellow ON (4.5s) → green ON (6..10s) → OFF	Binding with Access Point successful
Open CLEAN cover (SW2)	Red ON (approx. 1s) → green ON (approx. 0.5s)	CLEAN mode activated
Reset procedure	Green ON (approx. 2..3s) → OFF (approx. 6..7s) → yellow ON (approx. 2..3s) → OFF (approx. 1s) → yellow flashing (approx. 1s)	Sensor being reset

Reset procedure and assign default serial address	Green ON (approx. 2..3s) → OFF (approx. 6..7s) → yellow (approx. 2..3s) → yellow flashing (depends on when the CLEAN door is closed) → OFF (approx. 1s) → yellow flashing (approx. 1s)	Reset sensor plus return serial address to default value
---	--	--

Tab. 2.c

Note: the LED is two-colour, red and green, which becomes yellow when both LEDs are on at the same time. There may be different shades of yellow due to different tolerance in the brightness of the red and green LEDs.

2.3 Sensor activation

When the sensor is put in SLEEP mode using the rTM SE handheld during the procedure to assign the serial address (no transmission-minimum power consumption), the sensor is effectively in standby; nothing is transmitted until movement of the CLEAN switch is activated (sleep status). Activation is not reversible, and the sensor will send the temperature measured every 16 min (default value) if the Access Point that the sensor has been bound to is switched on.

- To exit sleep mode, proceed as follows:
- Power up the Access Point;
 - Move the CLEAN switch to the ON position (SW2);
 - Make sure the red LED comes on for a few seconds;
 - When the red LED comes on immediately the CLEAN switch to the OFF position;
 - The LED on the sensor remains on until it has connected to the Access Point.
- If the operation fails, the sensor returns to sleep mode, if however it's successful normal operation will resume, with data being sent every 16 min. Check operation by stimulating the sensor.

Resetting the sensor in sleep mode

- If the sensor needs to be reset when in sleep mode (Access Point network parameters forgotten), proceed as follows:
- Move the CLEAN switch to the ON position (SW2);
 - Wait for the red LED to come on;
 - Stimulate SW1 continuously while the red LED remains on.
 - Keep SW1 stimulated until the LED flashes (yellow);
 - Remove the magnet from SW1 and move switch SW2 back down.
 - Reset completed.

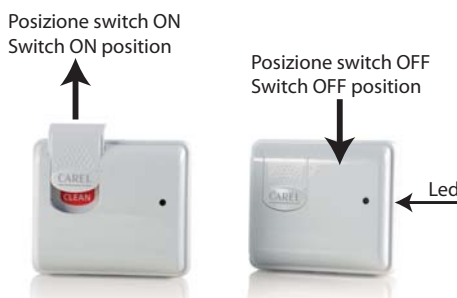

Fig. 2.c

Parameters and functions

The BP wireless sensor reads the temperature and manages the associated alarms at one minute intervals. The data is then transmitted at the intervals set by parameter, according to the application and the expected battery life. The sensors work most of the time in low power mode, so as to save battery power. They are activated to make the measurements and send the data at the preset time. Activate switch SW1 to send the sensor data manually, or check the connection. The CLEAN button is used to set cleaning status or deactivate the showcase, thus disabling the high temperature alarms. When returning from CLEAN mode, the high temperature alarms are disabled for a time equivalent to the auto-configuration cycle (AUTO_DELAY).

The sensor takes individual instant temperature measurements, however can also provide a weighted average, used to better approximate the product temperature. The logic for the alarms and all the other functions depends on the instant temperature measurement.

Wireless communication is activated automatically in the following situations:

- moving the CLEAN mode switch (SW2);
- stimulating the magnetic switch (SW1).

In all other cases, data transmission is defined by the set transmission cycle.

Note:

- The temperature measurement, with the update of the instant and average values, is performed at 1 minute intervals.

Important: the value is displayed on the supervisor after the set sensor transmission time .

The average temperature value is calculated using the following formula:

$$\text{Temp_AVG} = (\text{Temp_AVG-1} * (\text{M} - 1) + \text{Temp_Ist}) / \text{M}$$

Where:

- Temp_AVG-1 Previous average temperature value
- Temp_Ist Instant temperature measurement
- M Average weight (= AVERAGE_PARAM)

The average function also introduces an average measurement delay with a time constant equal to the average weight value (in minutes).

High temperature alarm function:

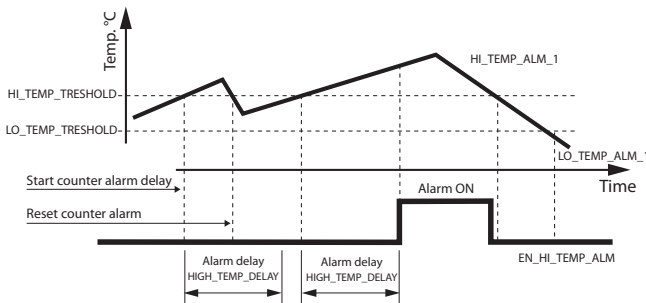

Fig. 2.d

- When the threshold is exceeded, the alarm is signalled only if this persists for a time greater than the delay set;
- If the temperature returns within the threshold before the delay time, the accumulated count is reset;
- The alarm is reset instantly when the temperature returns within the threshold.

Default values for the modes settable for the MODE_PARAM parameter

	MODE 0 Generic use	MODE 1 LOW showcases	MODE 2 MED showcases	MODE 3 MED shelf cases
High temp. threshold	-15 °C	-15 °C	+10 °C	+8 °C
Low temp. threshold	-40 °C	-40 °C	-2 °C	-2 °C
HACCP delay	180 min.	120 min.	120 min.	120 min.
Average weight	1 (Instant)	16 (16 min.)	8 (8 min.)	12 (12 min.)

Tab. 2.d

Automatic configuration procedure

The automatic recognition procedure is used to recognise the type of showcase and consequently configure the parameters for the showcase that the sensor is installed on. The automatic recognition cycle is activated (if enabled by EN_AUTO_CONF):

- When the temperature falls below the threshold MODE_AUTO_TRESH;
- When returning from CLEAN mode, closing the switch;
- When a previous cycle is completed.

When the AUTO_DELAY time has elapsed, if the following conditions are true:

- Final temperature rise less than 1°C/h;
- Final temperature within a fixed band of temperatures for the various types of showcase:
 - medium temp. showcases = from -2°C to + 6°C
 - low temp. showcases = less than -10°C.

The MODE_PARAM parameter is given the new value corresponding to the type of showcase and the associated values for the alarm thresholds, alarm delay and average weight are loaded;

Note:

- In the event of increases in temperature for low temperature showcases, the recognition procedure is disabled for 3 times the value of AUTO_DELAY, to avoid false recognitions.
- The temperature alarms are always enabled, if MODE_PARAM and consequently the associated parameters are changed, the alarm logic depends on the new parameters.
- The parameters associated with each mode (0-3) are saved separately and permanently, and are loaded automatically when the mode is changed.
- The values of the parameters associated with the mode must be set (by the supervisor) making sure that MODE_PARAM does not change, otherwise the values transferred may be ignored.

2.4 Technical specifications

Power supply	3.6V 2500 mAh lithium battery, "AA" size
Maximum power input	100 mW
Battery life in normal operating conditions	From 3 to 8 years, depending on the transmission time set. (CAREL is not responsible for the specified battery life)
Radio frequency specifications	Frequency: selectable from 2405 to 2480 MHz Power transmitted: 0dBm Wireless protocol: ZigBee
Operating conditions	-40T50°C
Storage conditions	-20T60°C humidity range: <80% RH non-condensing
Precision of temperature measurement	± 1 °C -10T30°C; ± 2 °C -30T40°C
Response time to temperature variations	> 20 minutes
Index of protection against atmospheric agents	IP65
Classification according to protection against electric shock appliances	Can be integrated into class I or class II appliances
Environmental pollution	Normal
PTI of insulating materials	250V
Period of stress across the insulating parts	Long
Category of resistance to heat and fire	category D (box and cover)
Immunity against voltage surges	category 1
Software class and structure	Class A
Disposal	observe local legislation for the disposal of electrical material
Product code	WS01U01M00 - Wireless sensor ver. BP SE IP65 -40 to 50°C WS01U01M01 Multiple pack of 20 WS01U01M00 sensors
Accessories	WS00BAT000 Battery WS00BAT200 Battery with connector for WS01U01M0* from rev. 4.802 WS00B01000 Plastic case only 000000722 Magnet for activating SW1

Tab. 2.e

2.5 List of parameters and variables, BP SE Sensor

Below is the table of supervisor parameters for the BP SE Sensor.

Modbus registers	Name	Description	Def.	Min	Max	UoM	"Type R/W"
HR0	'CMD_PASSW_1'	'Command Password (1)'	0	0	65535	-	R/W
HR1	'TRANSM_CYCLE'	'TX data cycle time'	960	60	3600	sec	R/W
HR2	'HI_TEMP_TRESHOLD'	'Threshold high Temp.'	-150	-400	500	0,1°C	R/W
HR3	'LO_TEMP_TRESHOLD'	'Threshold low Temp.'	-400	-400	500	0,1°C	R/W
HR4	'HIGH_TEMP_DELAY'	'Delay High Temp. Alarm'	120	0	254	min	R/W
HR5	'MODE_AUTO_TRESH'	'Threshold Auto Temp.'	120	0	500	min	R/W
HR6	'AVERAGE_PARAM'	'Parameter Avg-readings'	16	1	60	-	R/W
HR7	'AUTO_DELAY'	'Delay for AUTO-Config'	120	2	254	min	R/W
HR8	'MODE_PARAM'	'Par. MODE for cabinets'	1	0	3	-	R/W
HR9	'OFFS_TEMP'	'Offset Temperature Measure'	0	-99	99	0,1°C	R/W
HR10	'MIN_RSSI_LEVEL'	'Minimum rssi level counted (internal use)'	0	0	99	-	R/W
HR11	'CNT_REJOIN'	'Max counter value before rejoin (internal use)'	30	1	255	-	R/W
IR0	'MACHINE_CODE'	'Unit type - machine code'	63	-	-	-	R
IR1	'FW_VERSION'	'Firmware version (Major/Minor)'	2051	-	-	-	R
IR2	'TX_MESSAGE_CNT'	'Total Number of TX radio messages'	0	0	65535	-	R
IR3	'RX_MSG_LEVEL'	'Radio signal Level'	0	0	100	dBm+100	R
IR4	'ID_SER_ADDR'	'Carel_ID Serial_Address_DIP-SW value'	-	16	127	-	R
IR5	'BATTERY_LEVEL'	'Battery Level'	-	0	3600	mV	R
IR6	'AVG_TEMPERATURE'	'Temperature average Value'	-	-500	1000	0,1°C	R
IR7	'TEMPERATURE'	'Temperature Value'	-	-500	1000	0,1°C	R
IR8	'BATTERY_CHARGE'	'Counter battery remaining charge'	-	0	65535	-	R
IR9	'MAC_ADDR_0'	'Unit unique identifier Mac-Address LSB'	-	0	65535	-	R
IR10	'MAC_ADDR_1'	'Unit unique identifier Mac-Address MSB'	-	0	65535	-	R
IR11	'LAST_RX_DELAY'	'Time from last AP Rx message'	-	0	65535	-	R
IR12	'RX_MESSAGE_CNT'	'Counter - AP Rx messages'	-	0	65535	-	R
IR13	'TIME_STAMP'	'Time stamp for Temp. readings (100*hour+minute)'	-	0	2359	-	R
IR14	'AP_RX_RADIO_LEV'	'Radio Lev. for AP Rx messages'	-	0	100	dBm+100	R
IR15	'NETWORK_ID'	'Network address'	-	0	65535	-	R
IR16	'MIRROR_IS'	'Mirror Input Status (internal use)'	-	0	65535	-	R
CS0	'EN_CMD_PW'	'Trig. PWD (internal use)'	0	0	1	-	R/W
CS1	'EN_HI_TEMP_ALM'	'Enable High Temp. Alarm'	1	0	1	-	R/W
CS2	'EN_AUTO_CONF'	'Enable auto configuration MODE'	0	0	1	-	R/W
CS3	'EN_SCAFFALE'	'Type of cabinet (1= scaffale)'	0	0	1	-	R/W
IS0	'ALM_BATTERY'	'Battery Alarm'	-	0	1	-	R
IS1	'ALM_GENERAL'	'Unit General Alarm'	-	0	1	-	R
IS2	'ALM_PROBE_1'	'Temperature sensor Alarm'	-	0	1	-	R
IS3	'HI_TEMP_ALM_1'	'High Temperature Alarm'	-	0	1	-	R
IS4	'LO_TEMP_ALM_1'	'Low Temperature Alarm'	-	0	1	-	R

Tab. 2.f

For further information, see page 34

Key:

- HR = Holding register
- IR = Input register
- CS = Coil Status
- IS = Input Status

2.6 Installation notes

The sensor is installed on the bracket supplied as follows:

1. Fasten the bracket to the wall with two screws, supplied together with the sensor, considering that the unit being installed is a radio device, and thus taking the necessary precautions;
2. Couple the sensor to the bracket, making sure it clicks and locks into place.

N.B. To remove the sensor from the bracket, lift the release spring using a suitable screwdriver and lift the sensor.

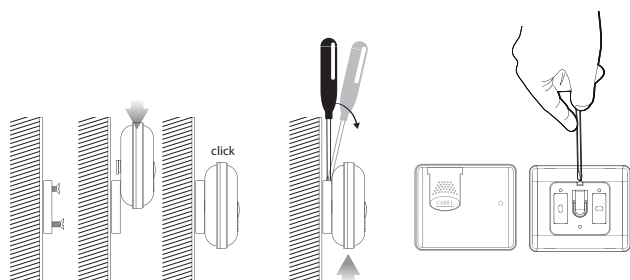

Fig. 2.e

2.7 Physical dimensions

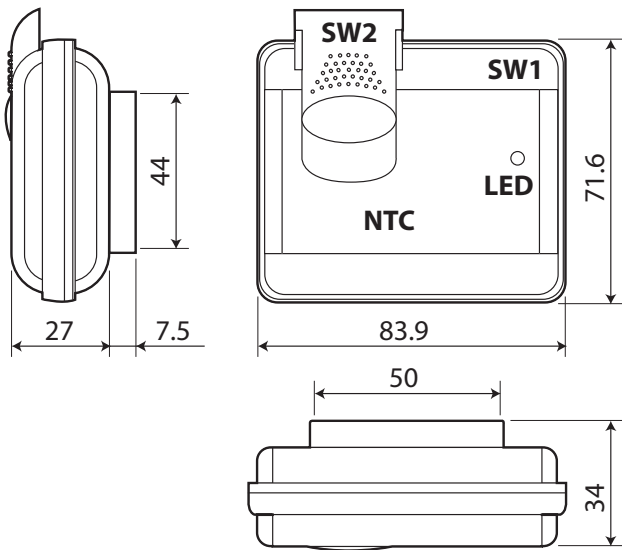

Fig. 2.f

2.8 Replacing the battery in the BP SE Sensor

The case of the BP SE wireless sensor has been designed to provide high protection. When opening the two plastic shells to replace the battery, the locking catches may be damaged or break. Consequently, the spare battery is supplied together with a new case. Take maximum care when removing the electronic board from the old shell and placing it in the new one, so as to not damage the electronic components. Make sure battery polarity is correct. Remove the product label from the old case and place it on the new one or apply a new one with the same data.

For replacement, proceed as follows:

3. Open the plastic shell;
4. Remove the existing battery;
5. Remove the electronic board and thermal insulator and insert the new shell (top);
6. Insert the new battery, checking the polarity;
7. Apply the gasket on the edge between the two shells;
8. Close the case with the shell (bottom), applying enough pressure to secure them together.

Rules for disposing of the battery

Do not dispose of the product as municipal waste; it must be disposed of through specialist waste disposal centres.

The product contains a battery that must be removed and separated from the rest of the product.

Improper use or incorrect disposal of the product may have negative effects on human health and on the environment.

The public or private waste collection systems defined by local legislation must be used for disposal.

In the event of illegal disposal of electrical and electronic waste, the penalties are specified by local waste disposal legislation.

2.9 Application examples

Supermarket showcases

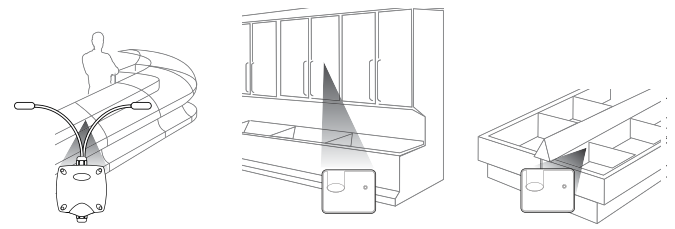

Fig. 2.g



Fig. 2.h

Example of supermarket layout and installation connections

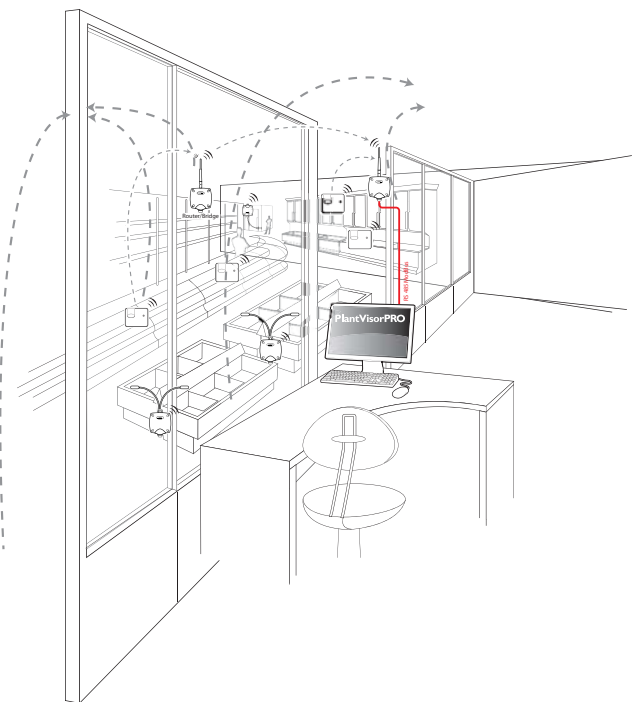

Fig. 2.i

3. EP SE, SA, SI SENSORS AND CI PULSE COUNTER

This section provides all the information common to the devices whose serial ID is configured by dipswitch. Refer to the specific instructions for each device.



Fig. 3.a

3.1 Parameters and functions

The wireless devices read the temperature and manage the associated alarms at intervals set by the transmission time parameter, according to the application and the expected battery life. The sensors work most of the time in low power mode, so as to save battery power. Press the button or stimulate the magnetic switch to send the sensor data manually, or check the connection.

3.2 Description of the acquisition process

The devices acquire all the values before sending their status to the Access Point. Consequently, the device sampling interval is equal to the transmission time.

3.3 Device configuration

Select the desired network address using the 8 dipswitches (0=OFF; 1=ON) as shown in the table. The possible sensor addresses are from 16 to 126.

Address	Dipswitch								Notes
	1	2	3	4	5	6	7	8	
0..15	x	x	x	x	x	x	x	x	address not allowed (*)
16	0	0	0	0	1	0	0	0	
17	1	0	0	0	1	0	0	0	
18	0	1	0	0	1	0	0	0	
19	1	1	0	0	1	0	0	0	
20	0	0	1	0	1	0	0	0	
...127	0	1	1	1	1	1	1	1	Reserved. Do not use
128...199	1	1	1	0	0	0	1	1	address not allowed (*)
200...256	x	x	x	x	x	x	x	x	address not allowed (*)

Tab. 3.a

For the complete list see the table at the end of the manual.

(*) The address may be set however the device cannot connect to the Access Point/Router. Pressing the button the LED flashes quickly in sequence to indicate an invalid address.

EXAMPLE required sensor address setting 117:

Decimal value: 117

Conversion to binary notation:(MSB) 0111 0101 (LSB)

Reverse the value of the string (10101110) and assign dipswitches from (LSB) 1 to 8. (MSB).

Dipswitch							
1	2	3	4	5	6	7	8
x	x	x	x	x	x	x	x
0	0	0	0	1	0	0	0
1	0	0	0	1	0	0	0
0	1	0	0	1	0	0	0
1	1	0	0	1	0	0	0
0	0	1	0	1	0	0	0
0	1	1	1	1	1	1	1
1	1	1	0	0	0	1	1
x	x	x	x	x	x	x	x

Tab. 3.b

3.4 Binding procedure

Binding is a special procedure used to associate the sensors with the Access Point. Once completed, the sensors will send the temperature data measure wirelessly only to the Access Point defined as its parent. Following this, the Access Point will forward the data to the Modbus® RTU RS485 serial network. Before performing this operation, make sure that the sensor serial address has been set.

After having opened the domain on the Access Point (see the instructions in the chapter on the Access Point), proceed as follows on the sensor:

Remove the protection from the contact on the battery to power up the device;

Check that the LED comes on for a few seconds with brief flashes.

Press the button once or activate the magnetic switch. Pressing it again activates a procedure to check the quality of the wireless signal (see the chapter "Analysing wireless signal quality");

LED L1 on the sensor remains on until connection to the Access Point is complete, flashing for around 10s, then L1, L2 and L3 flash together for a few seconds (wireless network connection).

The procedure for analysing wireless signal quality then starts for around 1 minute. The following come on in sequence:

1. L1 Indicates wireless transmission has occurred;
2. L1-L2 Indicates the signal has been received by the Access Point;
3. L3 flashes from 1 to 3 times, based on the quality of the wireless signal;
 - 1 flash, wireless connection with minimum signal strength;
 - 2 flashes, wireless connection with medium signal strength;
 - 3 flashes, wireless connection with excellent signal strength;

Button T1 is connected in parallel with the magnetic switch. The case does not need to be opened to stimulate the sensor for communication

Note: if LED L1 flashes once instead of remaining on, it means that the sensor has already been bound to an Access Point. In this case, reset the sensor (see Resetting the devices)

The Access Point shows that connection has been made by LED L3 coming on for around 1s., even if another node in the network is sending a message. Check the configuration: the sensor will be correctly bound if whenever the button is pressed or the magnetic switch is activated, the LEDs come on for a 1 min sequence.

- L1, on for 1s;
- L1-L2, on for 1s;
- L3, flashes from 1 to 3 times, based on the quality of the wireless signal;
 - 1 flash, wireless connection with minimum signal strength;
 - 2 flashes, wireless connection with medium signal strength;
 - 3 flashes, wireless connection with excellent signal strength;

For the EP SE Sensor, in normal operation LED L1 flashes for 1s every 20s. In general, for the other devices, the LED comes on whenever data is sent, and consequently based on the device transmission time.

Important: the sensor binding operation may fail if:

- the distances are high and/or there is infrastructure that does not allow communication between the devices (see the example of sensor S2 in Figure 4.c);
- the maximum limit of sensors allowed for the Access Point has been reached (max 30). In this case, an additional Router-Bridge is needed for up to a maximum of 60 sensors.

3.5 Resetting the sensor (unbinding)

The reset procedure is required when the sensor needs to be moved and associated with another wireless network (different Access Point). This operation may be required to reconfigure the sensor in a different wireless network. The value of the serial address remains the same, unless the configuration dipperswitches are moved. After a new binding operation the sensor is reactivated in the wireless network. To reset the EP SE Sensor, proceed as follows:

1. Remove the battery (press the button to discharge any residual energy in the circuit) and replace the battery in its socket (LEDs L1, L2, L3 come on at the same time, then flash quickly and switch off).
2. Immediately after the LED have switched off (within a few seconds) press button T1 until the pairs of LEDs L1-L3 and L2 flash alternately.
3. Release the button. LEDs L1, L2, L3 will flash briefly and then switch off.

To make sure the sensor has effectively been reset:

1. Make sure the Access Point wireless network is closed (L1 flashes slowly 1s).
2. Press button T1 on the sensor and make sure LED L1 comes on and remains on for around 20 sec.

WARNING: The sensor has been unbound (reset) and maintains the same network address assigned.

To change the address, remove the battery, move dipperswitches 1 to 8, and replace the battery.

Note:

1. The sensor can only be reset if it has already been associated with an Access Point;
2. Resetting the sensor does not delete the space reserved inside the Access Point, which will continue to maintain the data saved inside. Note that, after resetting the sensor, the number of devices set for the Access Point remains unchanged. Realignment will occur after a maximum of around 2 hours.

Important: pay careful attention to avoid duplicate assignment of network serial addresses, so as to avoid overlapping temperature values.

The sensor is supplied with the battery already fitted, and with the positive pole insulated by a protective film; this must be removed after assigning the network serial address.

3.6 General warnings

When replacing the battery, strictly observe the following instructions. The battery may explode if replaced with another of an incorrect type. Dispose of the used batteries according to the standards in force; Install the sensor with the cable gland facing downwards;

Replacing the battery

Remove the cover, remove the battery, and replace with another of the same type. Close the cover again.

Rules for disposing of the battery

Do not dispose of the product as municipal waste; it must be disposed of through specialist waste disposal centres.

The product contains a battery that must be removed and separated from the rest of the product.

Improper use or incorrect disposal of the product may negative effects on human health and on the environment.

The public or private waste collection systems defined by local legislation must be used for disposal.

In the event of illegal disposal of electrical and electronic waste, the penalties are specified by local waste disposal legislation.

4. EP SENSOR (EXTERNAL PROBE)



Fig. 4.a

The EP SE Sensor is designed to be fitted inside showcases or cold rooms, and can house two external passive NTC temperature probes 10K@25°C (Beta(25/85) = 3435K) and two digital inputs to be used to monitor door and defrost status, or used as generic inputs.

4.1 Functions implemented

- Instant temperature measurement performed every minute, probe 1;
- Instant temperature measurement performed every minute, probe 2;
- Data transmission at a settable interval in minutes (this affects battery life);
- Monitoring of temperature thresholds for high temperature (HACCP) or low temperature (product freezing) alarm signals.

Main variables available to the supervisory system

- Probe 1 temperature;
- Probe 2 temperature;
- Battery level in mV ;
- Wireless signal level in dBm +100 (8 = low signal, 15 to 30 = medium signal, greater than 30 excellent).
- Temperature alarm status related to the high and low thresholds.
- Data transmission interval;
- Enable high temperature alarm;
- TimeStamp for recording the instant measurement, expressed in hh:mm;

4.2 Parameters and functions

The EP SE wireless sensors read the temperature and manage the associated alarms at intervals set by the transmission time parameter, according to the application and the expected battery life. The sensors work most of the time in low power mode, so as to save battery power. Press the button on the sensor to send the sensor data manually, or check the connection.

The main parameters and functions of the sensor are:

-Data transmission activation:

-Wireless transmission is activated in the following conditions:

- Change in status of the digital inputs, door and defrost;
- Change in status of the digital inputs, door and defrost;
- Temperature probe fault alarms;
- Briefly pressing the button.

In all other cases, data transmission is defined by the set transmission time.

Logical state of DOOR_POL and DEFROST_POL variables

The following table shows the logical state of the input based on the electrical state of the contact (open or closed).

Contact state	Polarity	Logical state of DOOR input
OPEN	1	Door CLOSED
CLOSED	1	Door OPEN
OPEN	0	Door OPEN
CLOSED	0	Door CLOSED

Tab. 4.a

DEFROST_IN_STATUS and DOOR_IN_STATUS = Provide the current logical state of the two digital inputs.

- 0 = Door CLOSED 1 = Door OPEN
- 0 = Defrost NOT Active 1 = Defrost Active

High temperature alarm function:

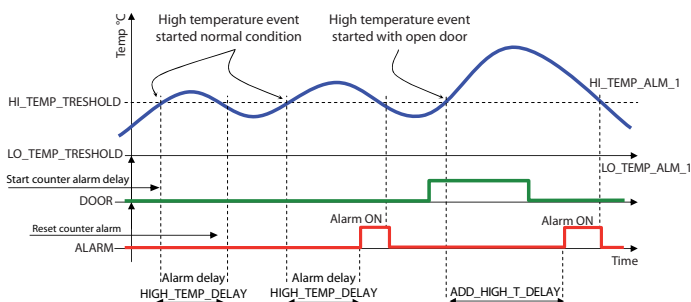

Fig. 4.a

The figure shows the high temperature alarm function:

1. when the threshold is exceeded, the alarm is signalled only if this persists for a time greater than the delay set;
2. if the temperature returns within the threshold before the delay time, the accumulated count is reset;
3. the alarm is reset instantly when the temperature returns within the threshold.

Enabling and disabling the digital inputs

Management of the door and defrost inputs can be enabled or disabled using EN_DI_DOOR for the door input and EN_DI_DEFROST for the defrost input.

If not enabled, the inputs are inactive (0). Even when disabled, however, the logical state of the digital inputs can be identified by reading the value of IN_1_STATUS for IN_1 (1=Active, 0=Not active) and IN_2_STATUS for input IN_2 (1=Active, 0=Not active). By default the door and defrost inputs are enabled.

The high temperature alarm is activated after the delay if the door input is active. For correct operation of the temperature alarm signals, the status of the door and defrost must always be read as inactive, even if the two inputs are not used. To return both to normal conditions, the value of the two polarity states can be set to 1 for the door (DOOR_POL) and defrost (DEFROST_POL), or alternatively the two inputs can be jumpered if not used.

Enable and disabling the analogue inputs

EN_NTC_1 and EN_NTC_2 enable and disable the probe inputs. The probe inputs can be enabled and disabled using parameters EN_NTC_1 and EN_NTC_2 respectively. If a probe input is disabled, the temperature reading is equal to 0°C; in this event, the probe alarm fault is not managed and remains constantly inactive (0). By default the probe inputs are enabled.

4.3 Technical specifications

Power supply	3.6V 2500 mAh lithium battery, "AA" size
Maximum power input	100 mW
Battery life in normal operating conditions	From 3 to 8 years, depending on the transmission time set. (CAREL is not responsible for the specified battery life)
Radio frequency specifications	Frequency: selectable from 2405 to 2480 MHz Wireless protocol: ZigBee Power transmitted: 0 dBm
Operating conditions	-40T50°C
Storage conditions	-20T60°C humidity range: <80% RH non-condensing
Precision of temperature measurement	± 1 °C -10T30°C; ± 2 °C -30T40°C
Response time to temperature variations	> 20 minutes Compliant with EN 13485
Index of protection against atmospheric agents	IP65
Classification according to protection against electric shock	Can be integrated into class I or class II appliances
Environmental pollution	Normal
PTI of insulating materials	250 V
Period of stress across the insulating parts	Long
Category of resistance to heat and fire	category D (box and cover)
Immunity against voltage surges	category 1
Software class and structure	Class A
Disposal	observe local legislation for the disposal of electrical material
Product code	WS01W02M00 - Wireless sensor ver. EP SE battery powered 2NTC- 2DI -50 to 90°C
Accessories	WS00BAT000 - Battery, single package 0000000722 Magnet for activating SW1

Tab. 4.b

Note: the index of protection is maintained only if a single cable is used for power and RS485 communication with an outside cross-section of less than 8 mm.

4.4 List of parameters and variables, EP SE Sensor

Below is the table of supervisor parameters for the model EP SE sensors, and also applies to the EP1 Router-Sensor (only for the special sensor function).

Modbus registers	Name	Description	Def.	Min	Max	UoM	"Type R/W"
HR0	'CMD_PASSW_1'	'Command Password (1)'	0	0	65535	-	R/W
HR1	'TRANSM_CYCLE'	'TX data cycle time'	960	20	3600	sec	R/W
HR2	'HI_TEMP_TRESHOLD_1'	'Threshold high Temp. probe 1'	220	-500	500	0,1°C	R/W
HR3	'LO_TEMP_TRESHOLD_1'	'Threshold low Temp. probe 1'	-500	-500	500	0,1°C	R/W
HR4	'HI_TEMP_TRESHOLD_2'	'Threshold high Temp. probe 2'	220	-500	500	0,1°C	R/W
HR5	'LO_TEMP_TRESHOLD_2'	'Threshold low Temp. probe 2'	-500	-500	500	0,1°C	R/W
HR6	'HIGH_TEMP_DELAY'	'Delay High temperature Alarm'	1	1	254	min	R/W
HR7	'DEFROST_ALM_DELAY'	'Delay long defrost Alarm'	1	1	254	min	R/W
HR8	'MIN_RSSI_LEVEL'	'Minimum rssi level counted (internal use)'	0	0	99	-	R/W
HR9	'CNT_REJOIN'	'Max counter value before rejoin (internal use)'	30	1	255	-	R/W
HR10	'OFFS_TEMP_1'	'Offset Temperature 1 Measure'	0	-99	99	0,1°C	R/W
HR11	'OFFS_TEMP_2'	'Offset Temperature 2 Measure'	0	-99	99	0,1°C	R/W
HR12	'ADD_HIGH_T_DELAY'	'Additional High Temperature Alarm Delay(min)'	10	1	254	min	R/W
IR0	'MACHINE_CODE'	'Unit type - machine code'	62/64	-	-	-	R
IR1	'FW_VERSION'	'Firmware version (Major/Minor)'	2051	-	-	-	R
IR2	'TX_MESSAGE_CNT'	'Total Number of TX radio messages'	0	0	65535	-	R
IR3	'RX_MSG_LEVEL'	'Radio signal Level'	-	0	100	dBm+100	R
IR4	'ID_SER_ADDR'	'Carel_ID Serial_Address DIP-SW value'	-	16	247	-	R
IR5	'BATTERY_LEVEL'	'Battery Level'	-	0	3600	mV	R
IR6	'TX_POWER'	'Transmission power'	3/10	-	-	dBm+100	R
IR7	'TEMPERATURE_1'	'Temperature Value probe 1'	-	-500	1000	0,1°C	R
IR8	'TEMPERATURE_2'	'Temperature Value probe 2'	-	-500	1000	0,1°C	R
IR9	'MAC_ADDR_0'	'Unit unique identifier Mac-Address LSB'	-	0	65535	-	R
IR10	'MAC_ADDR_1'	'Unit unique identifier Mac-Address MSB'	-	0	65535	-	R
IR11	'LAST_RX_DELAY'	'Time from last AP Rx message'	-	0	65535	sec	R
IR12	'RX_MESSAGE_CNT'	'Counter - AP Rx messages'	-	0	65535	-	R
IR13	'TIME_STAMP'	'Time stamp for Temp. readings (100*hour+minute)'	-	0	2359	-	R
IR14	'AP_RX_RADIO_LEV'	'Radio Lev. for AP Rx messages'	-	0	100	dBm+100	R
IR15	'NETWORK_ID'	'Network address'	-	0	65535	-	R
IR16	'MIRROR_IS'	'Mirror Input Status (internal use)'	-	0	65535	-	R
CS0	'EN_CMD_PW'	'Trig. PWD (internal use)'	0	0	1	-	R/W
CS1	'EN_HI_TEMP_ALM'	'Enable High Temperature Alarm'	1	0	1	-	R/W
CS2	'DOOR_POL'	'Door digital input polarity'	0	0	1	-	R/W
CS3	'DEFROST_POL'	'Defrost digital input polarity'	0	0	1	-	R/W
CS4	'EN_NTC_1'	'Enable Probe NTC_1'	1	0	1	-	R/W
CS5	'EN_NTC_2'	'Enable Probe NTC_2'	1	0	1	-	R/W
CS6	'EN_DI_DOOR'	'Enable Input Door'	1	0	1	-	R/W
CS7	'EN_DI_DEFROST'	'Enable Input Defrost'	1	0	1	-	R/W
IS0	'HI_TEMP_ALM_1'	'High Temperature 1 Alarm'	-	0	1	-	R
IS1	'LO_TEMP_ALM_1'	'Low Temperature 1 Alarm'	-	0	1	-	R
IS2	'HI_TEMP_ALM_2'	'High Temperature 2 Alarm'	-	0	1	-	R
IS3	'LO_TEMP_ALM_2'	'Low Temperature 2 Alarm'	-	0	1	-	R
IS4	'DEFROST_IN_STATUS'	'Defrost input status (1 = open)'	-	0	1	-	R
IS5	'DOOR_IN_STATUS'	'Door input status (1 = open)'	-	0	1	-	R
IS6	'ALM_PROBE_1'	'Temperature sensor 1 Alarm'	-	0	1	-	R
IS7	'ALM_PROBE_2'	'Temperature sensor 2 Alarm'	-	0	1	-	R
IS8	'ALM_GENERAL'	'General Unit Alarm'	-	0	1	-	R
IS9	'ALM_BATTERY'	'Battery Alarm'	-	0	1	-	R
IS10	'ALM_LONG_DEFROST'	'Long Defrost Alarm'	-	0	1	-	R
IS11	'IN_1_STATUS'	'Digital Input State IN_1 (1=active 0=no active)'	-	0	1	-	R
IS12	'IN_2_STATUS'	'Digital Input State IN_2 (1=active 0=no active)'	-	0	1	-	R

Tab. 4.c

For further information, see page 34

Key:

- HR= Holding register
- IR= Input register
- CS= Coil Status
- IS= Input Status

4.5 EP SE Sensor installation notes

1. Remove the cover by unscrewing the four screws at the front.
2. Fasten the case to the wall with minimum two screws, remembering that this is a radio device and therefore the necessary details must be observed.
3. Connect the two NTC temperature probes (10K@25°C Beta(25/85) = 3435K) to the terminals provided.
4. Connect the two digital inputs to the terminals provided (door and defrost).
5. Select the network address on the dipswitches.
6. Remove the insulating protection on the battery.
7. Perform the binding procedure.
8. Check the quality of the wireless signal; stimulate the sensor by pressing button T1 or activating magnetic switch SW1 and check the flashes on LED L3:
 - 1 flash, wireless connection with minimum signal strength;
 - 2 flashes, wireless connection with medium signal strength;
 - 3 flashes, wireless connection with excellent signal strength;
9. Close the sensor again.
10. Make sure that the transmitter is in an optimum position with reference to the receiver, once installation is complete, checking the transmitted signal level in the corresponding supervisor variable.

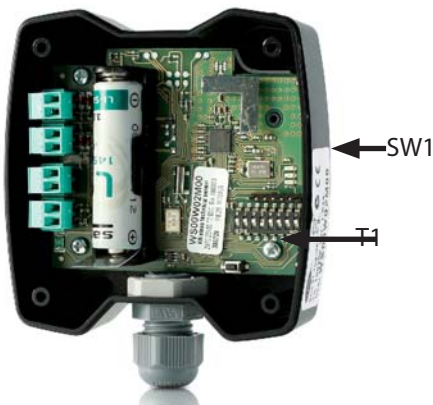

Fig. 4.b

4.6 EP SE physical dimensions

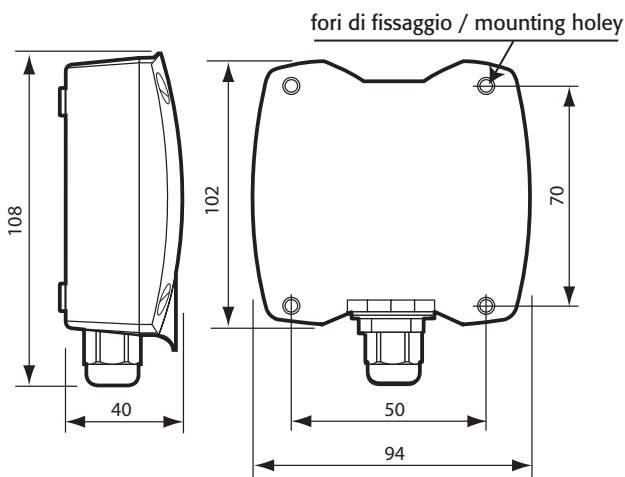

Fig. 4.c

4.7 EP SE electrical connections

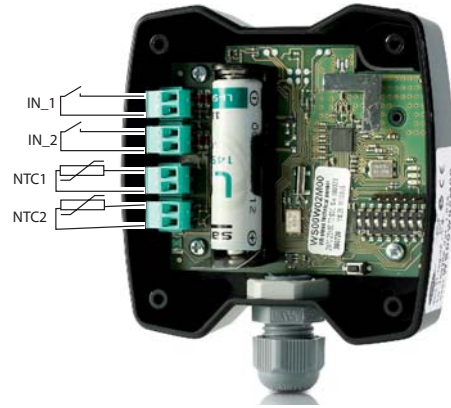

Fig. 4.d

1. Probe input NTC_1 10K@25°C Beta(25/85) = 3435K (e.g. NTC*HP* or NTC*WP*);
 2. Probe input NTC_2 10K@25°C Beta(25/85) = 3435K (e.g. NTC*HP* or NTC*WP*);
 3. Defrost digital input (can be configured N.C. or N.O);
 4. Door digital input (can be configured N.C. or N.O);
- The maximum cable length for NTC probes and digital inputs is 10 m.

4.8 Application example

EP SE sensors are typically used to monitor the temperature in cold rooms.

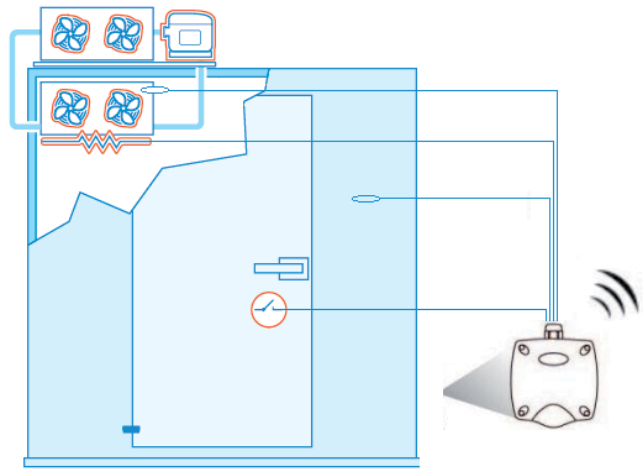

Fig. 4.e

5. SA ROOM SENSOR



The SA Sensor is used to measure room temperature and humidity in residential applications. It features one temperature probe and one humidity probe to measure ambient conditions, and sends the data measured to the Access Point at regular intervals.

Fig. 5.a

5.1 Functions implemented and supervisor variables available

Parameters and functions

- Temperature measurement performed every transmission cycle;
- Humidity measurement performed every transmission cycle;
- Temperature alarm when exceeding the minimum and maximum thresholds set by parameter;
- Humidity alarm when exceeding the minimum and maximum thresholds set by parameter;
- Low battery level alarm;
- Data transmission at settable interval in minutes (this affects battery life);

Main variables available to the supervisory system

- Temperature;
- Humidity;
- Battery level in mV ;
- Wireless signal level in dBm +100 (8 = low signal, 15 to 30 = medium signal, greater than 30 excellent).
- Temperature and humidity alarm status relative to high and low thresholds.
- Data transmission interval;
- TimeStamp for recording the instant measurement, expressed in hh:mm;

Temperature alarm function:

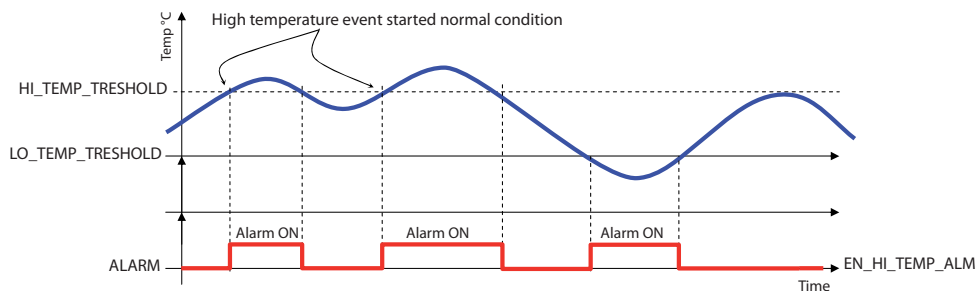

Fig. 5.a

Humidity alarm function:

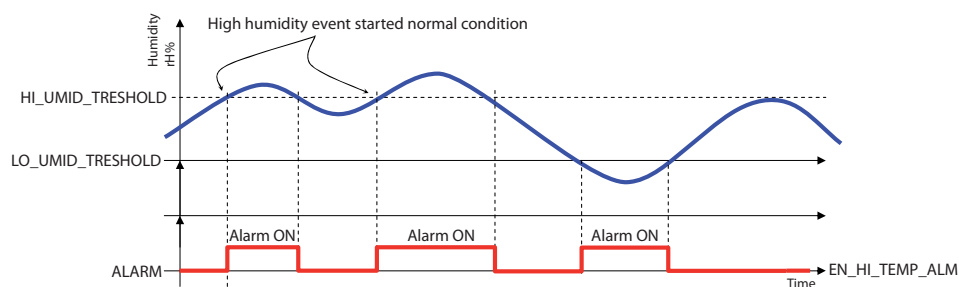

Fig. 5.b

The sensor compares the temperature and humidity measured against the parameters that define the alarm limits.

There are no delays in activating the alarm signal; as soon as the acquired value is higher than the maximum limit or lower than the minimum limit the corresponding flag is activated.

If Temperature > High temperature limit --> high temp. alarm =1

If Temperature ≤ High temperature limit --> high temp. alarm =0

If Temperature < Low temperature limit --> low temp. alarm =1

If Temperature ≥ Low temperature limit --> low temp. alarm =0

If Humidity > Maximum humidity limit --> maximum humidity alarm =1

If Humidity ≤ Maximum humidity limit --> maximum humidity alarm =0

If Humidity < Minimum humidity limit --> minimum humidity alarm =1

If Humidity ≥ Minimum humidity limit --> minimum humidity alarm =0

5.2 Technical specifications

Power supply	3.6V 2500 mAh lithium battery, "AA" size
Maximum power input	100 mW
Battery life in normal operating conditions	From 3 to 8 years, depending on the transmission time set. (CAREL is not responsible for the specified battery life)
Radio frequency specifications	Frequency: selectable from 2405 to 2480 MHz Power transmitted: 0dBm Wireless protocol: ZigBee
Operating conditions	-10T60 °C 10 to 90 rH%
Storage conditions	-20T70 °C - humidity range: <80% RH non-cond.
Precision of temperature measurement and humidity	Temperature ±1°C 0T50 °C Humidity ±5 rH%
Index of protection against atmospheric agents	IP30
Classification according to protection against electric shock	Can be integrated into class I or class II appliances
Environmental pollution	Normal
PTI of insulating materials	250 V
Period of stress across the insulating parts	Long
Category of resistance to heat and fire	category D (box and cover)
Immunity against voltage surges	category 1
Software class and structure	Class A
Disposal	observe local legislation for the disposal of electrical material
Product code	WS01G01M00 - Wireless room temperature and humidity sensor ver. SA battery powered
Accessories	WS00BAT000 - Battery, single package 0000000722 Magnet for activating SW1

Tab. 5.a

5.3 List of parameters and variables, SA Sensor

Modbus registers	Name	Description	Def.	Min	Max	UoM	"Type R/W"
HR0	CMD_PASSW_1	'Command Password (1)'	0	0	65535	-	R/W
HR1	TRANSM_CYCLE	'TX data cycle time'	60	5	3600	sec	R/W
HR2	LO_TEMP_TRESHOLD	'Threshold low Temp.'	-500	-500	1000	0,1°C	R/W
HR3	HI_TEMP_TRESHOLD	'Threshold high Temp.'	1000	-500	1000	0,1°C	R/W
HR6	LO_UMID_TRESHOLD	'Threshold low Umidity'	0	0	100	%Ur	R/W
HR7	HI_UMID_TRESHOLD	'Threshold high Umidity'	100	0	100	%Ur	R/W
HR9	OFFS_TEMP	'Offset Temperature Measure'	0	-100	100	0,1°C	R/W
HR10	UNIT_MIS	'Temperature unit of measure (0=Celsius; 1=Fahrenheit)'	0	0	1	-	R/W
HR11	MIN_RSSI_LEVEL	'Minimum rssi level counted (internal use)'	0	0	99	-	R/W
HR12	CNT_REJOIN	'Max counter value before rejoin (internal use)'	30	1	255	-	R/W
IR0	MACHINE_CODE	'Unit type - machine code'	66	-	-	-	R
IR1	FW_VERSION	'Firmware version (Major/Minor)'	2051	-	-	-	R
IR2	TX_MESSAGE_CNT	'Total Number of TX radio messages'	0	0	65535	-	R
IR3	RX_MSG_LEVEL	'Radio signal Level'	-	0	100	dBm+100	R
IR4	BATTERY_LEVEL	'Battery Level'	-	0	3600	mV	R
IR6	TEMPERATURE	'Temperature Value'	-	-500	1000	0,1°C	R
IR8	UMIDITY	'Umidity Value'	-	0	100	%Ur	R
IR9	MAC_ADDR_0	'Unit unique identifier Mac-Address LSB'	-	0	65535	-	R
IR10	MAC_ADDR_1	'Unit unique identifier Mac-Address MSB'	-	0	65535	-	R
IR11	ID_SER_ADDR	'Carel_ID, Serial_Address, DIP-SW value'	-	16	127	-	R
IR12	LAST_RX_DELAY	'Time from last Access Point Rx message'	-	0	65535	-	R
IR13	RX_MESSAGE_CNT	'Counter - AP Rx messages'	-	0	65535	-	R
IR14	TIME_STAMP	'Time stamp for Temp. readings (100*hour+minute)'	-	0	2359	hh*100+mm	R
IR15	AP_RX_RADIO_LEV	'Radio Lev. for AP Rx messages'	-	0	100	dBm+100	R
IR16	NETWORK_ID	'Network address'	-	0	65535	-	R
IR17	'MIRROR_IS'	'Mirror Input Status (internal use)'	-	0	65535	-	R
CS0	EN_CMD_PW	'Trig. PWD (internal use)'	0	0	1	-	R/W
IS0	HI_TEMP_ALARM	'High Temperature Alarm'	-	0	1	-	R
IS1	LO_TEMP_ALARM	'Low Temperature Alarm'	-	0	1	-	R
IS4	HI_UMID_ALARM	'High Umidity Alarm'	-	0	1	-	R
IS5	LO_UMID_ALARM	'Low Umidity Alarm'	-	0	1	-	R
IS6	PROBE_ERROR	'Probe Failure Alarm'	-	0	1	-	R
IS7	LOW_BATT	'Battery Alarm'	-	0	1	-	R

Tab. 5.b

For further information, see page 34

Key:

HR= Holding register

IR= Input register

CS= Coil Status

IS= Input Status

5.4 Sensor installation notes

1. Remove the cover.
2. Fasten the case to the wall with minimum two screws, remembering that this is a radio device and therefore the necessary details must be observed.
3. Select the network address on the dipswitches.
4. Remove the insulating protection on the battery.
5. Perform the binding procedure.
6. Check the quality of the wireless signal; stimulate the sensor by pressing button T1 or activating magnetic switch SW1 and check the flashes on LED L3:
 - 1 flash, wireless connection with minimum signal strength;
 - 2 flashes, wireless connection with medium signal strength;
 - 3 flashes, wireless connection with excellent signal strength;
7. Close the sensor again.
8. Make sure that the transmitter is in an optimum position with reference to the receiver, once installation is complete, checking the transmitted signal level in the corresponding supervisor variable.



Fig. 5.c

5.5 Physical dimensions

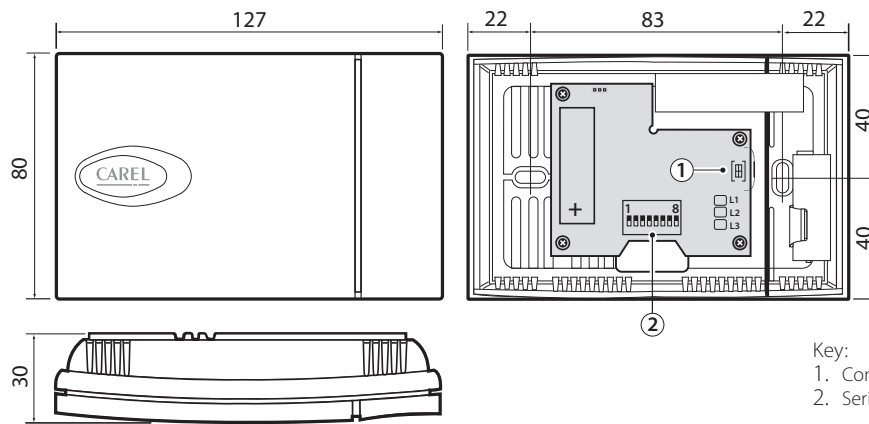

Fig. 5.d

5.6 Application example



Fig. 5.e

6. SI INDUSTRIAL SENSOR



Fig. 6.a

The SI Sensor is used to measure the temperature, humidity and light intensity in residential or light industrial applications. It features one temperature probe, one humidity probe and one light intensity sensor to measure ambient conditions, and sends the data measured to the Access Point at regular intervals.

6.1 Functions implemented and supervisor variables available

Parameters and functions

- Temperature measurement performed every transmission cycle;
- Humidity measurement performed every transmission cycle;
- Light intensity measurement performed every transmission cycle;
- Temperature alarm when exceeding the minimum and maximum thresholds set by parameter;
- Humidity alarm when exceeding the minimum and maximum thresholds set by parameter;
- Light intensity alarm when exceeding the minimum and maximum thresholds set by parameter;
- Low battery level alarm;
- Data transmission at settable interval in minutes (this affects battery life);

Main variables available to the supervisory system

- Temperature;
- Humidity;
- Light intensity;
- Battery level in mV ;
- Wireless signal level in dBm +100 (8 = low signal, 15 to 30 = medium signal, greater than 30 excellent).
- Temperature, humidity and light alarm status relative to high and low thresholds.
- Data transmission interval;
- TimeStamp for recording the instant measurement, expressed in hh:mm.

Temperature alarm function:

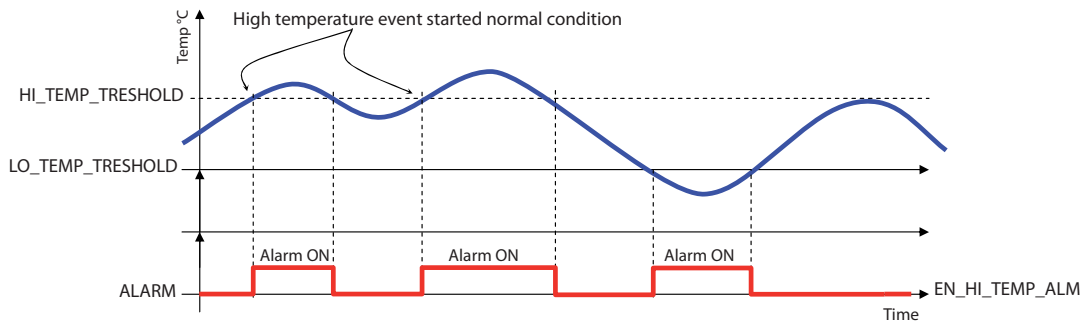

Fig. 6.b

Humidity alarm function:

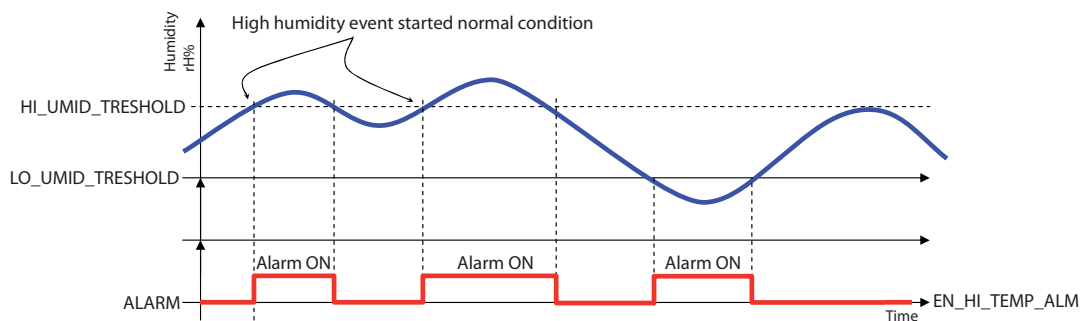

Fig. 6.c

Light intensity alarm function:

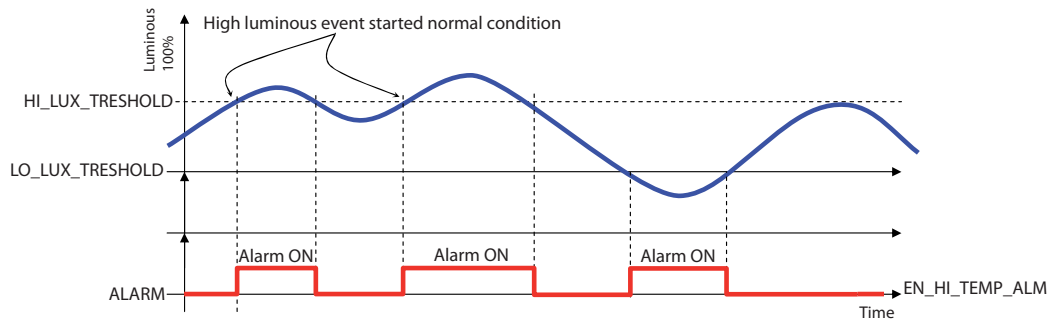

Fig. 6.d

The sensor compares the temperature, humidity and light intensity measured against the parameters that define the alarm limits. There are no delays in activating the alarm signal; as soon as the acquired value is higher than the maximum limit or lower than the minimum limit the corresponding flag is activated.

If Temperature > High temperature limit --> high temp. alarm =1
 If Temperature ≤ High temperature limit --> high temp. alarm =0
 If Temperature < Low temperature limit --> low temp. alarm =1
 If Temperature ≥ Low temperature limit --> low temp. alarm =0

If Humidity > Maximum humidity limit --> maximum humidity alarm =1
 If Humidity ≤ Maximum humidity limit --> maximum humidity alarm =0
 If Humidity < Minimum humidity limit --> minimum humidity alarm =1
 If Humidity ≥ Minimum humidity limit --> minimum humidity alarm =0

If Light > Maximum light limit --> maximum light alarm =1
 If Light ≤ Maximum light limit --> maximum light alarm =0
 If Light < Minimum light limit --> minimum light alarm =1
 If Light ≥ Minimum light limit --> minimum light alarm =0

6.2 Technical specifications

Power supply	3.6V 2500 mAh lithium battery, "AA" size
Maximum power input	100 mW
Battery life in normal operating conditions	From 3 to 8 years, depending on the transmission time set. (CAREL is not responsible for the specified battery life)
Radio frequency specifications	Frequency: selectable from 2405 to 2480 MHz Power transmitted: 0dBm Wireless protocol: ZigBee
Operating conditions	-20T70 °C 10 to 90 rH% 0 to 100 (Light intensity)
Storage conditions	-20T70 °C - humidity range: <80% RH non-cond.
Precision of temperature measurement and humidity	Temperature ±1°C 0T50 °C Humidity ±5 rH% Light intensity ±20% (depends on the spectrum)
Index of protection against atmospheric agents	IP55
Classification according to protection against electric shock	Can be integrated into class I or class II appliances
Environmental pollution	Normal
PTI of insulating materials	250 V
Period of stress across the insulating parts	Long
Category of resistance to heat and fire	category D (box and cover)
Immunity against voltage surges	category 1
Software class and structure	Class A
Disposal	observe local legislation for the disposal of electrical material
Product code	WS01F01M00 - Wireless industrial temperature, humidity and light intensity sensor ver. SI battery powered
Accessories	WS00BAT000 - Battery, single package 0000000722 Magnet for activating SW1

Tab. 6.a

6.3 List of parameters and variables, SI Sensor

Below is the table of supervisor parameters for the SI Sensors.

Modbus registers	Name	Description	Def.	Min	Max	UoM	"Type R/W"
HR0	CMD_PASSW_1	'Command Password (1)'	0	0	65535	-	R/W
HR1	TRANSM_CYCLE	'TX data cycle time'	60	5	3600	sec	R/W
HR2	LO_TEMP_TRESHOLD	'Threshold low Temp.'	-500	-500	1000	0,1°C	R/W
HR3	HI_TEMP_TRESHOLD	'Threshold high Temp.'	1000	-500	1000	0,1°C	R/W
HR4	LO_LIGHT_TRESHOLD	'Threshold low Light'	0	0	10000	-	R/W
HR5	HI_LIGHT_TRESHOLD	'Threshold high Light'	100	0	10000	-	R/W
HR6	LO_UMID_TRESHOLD	'Threshold low Umidity'	0	0	100	%Ur	R/W
HR7	HI_UMID_TRESHOLD	'Threshold high Umidity'	100	0	100	%Ur	R/W
HR8	COEFF_LIGHT	'Light multiplicative coefficient'	1000	0	30000	-	R/W
HR9	OFFS_TEMP	'Offset Temperature Measure'	0	-100	100	0,1°C	R/W
HR10	UNIT_MIS	'Temperature unit of measure (0=Celsius; 1=Fahrenheit)'	0	0	1	-	R/W
HR11	MIN_RSSI_LEVEL	'Minimum rssi level counted (internal use)'	0	0	99	-	R/W
HR12	CNT_REJOIN	'Max counter value before rejoin (internal use)'	30	1	255	-	R/W
IR0	MACHINE_CODE	'Unit type - machine code'	65	-	-	-	R
IR1	FW_VERSION	'Firmware version (Major/Minor)'	2051	-	-	-	R
IR2	TX_MESSAGE_CNT	'Total Number of TX radio messages'	0	0	65535	-	R
IR3	RX_MSG_LEVEL	'Radio signal Level'	-	0	100	dBm+100	R
IR4	BATTERY_LEVEL	'Battery Level'	-	0	3600	mV	R
IR5	LIGHT_EFFIC	'RMS light'	-	0	65535	-	R
IR6	TEMPERATURE	'Temperature Value'	-	-500	1000	0,1°C	R
IR7	LIGHT	'Light'	-	0	65535	-	R
IR8	UMIDITY	'Umidity Value'	-	0	100	%Ur	R
IR9	MAC_ADDR_0	'Unit unique identifier Mac-Address LSB'	-	0	65535	-	R
IR10	MAC_ADDR_1	'Unit unique identifier Mac-Address MSB'	-	0	65535	-	R
IR11	ID_SER_ADDR	'Carel_ID, Serial_Address, DIP-SW value'	-	16	127	-	R
IR12	LAST_RX_DELAY	'Time from last Access Point Rx message'	-	0	65535	-	R
IR13	RX_MESSAGE_CNT	'Counter - AP Rx messages'	-	0	65535	-	R
IR14	TIME_STAMP	'Time stamp for Temp. readings (100*hour+minute)'	-	0	2359	hh*100+mm	R
IR15	AP_RX_RADIO_LEV	'Livello Radio messaggi Rx da AccessPoint'	-	0	100	dBm+100	R
IR16	NETWORK_ID	'Network address'	-	0	65535	-	R
IR17	'MIRROR_IS'	'Mirror Input Status (internal use)'	-	0	65535	-	R
CS0	EN_CMD_PW	'Trig. PWD (internal use)'	0	0	1	-	R/W
IS0	HI_TEMP_ALARM	'High Temperature Alarm'	-	0	1	-	R
IS1	LO_TEMP_ALARM	'Low Temperature Alarm'	-	0	1	-	R
IS2	HI_LIGHT_ALARM	'High Light Alarm'	-	0	1	-	R
IS3	LO_LIGHT_ALARM	'Low Light Alarm'	-	0	1	-	R
IS4	HI_UMID_ALARM	'High Umidity Alarm'	-	0	1	-	R
IS5	LO_UMID_ALARM	'Low Umidity Alarm'	-	0	1	-	R
IS6	PROBE_ERROR	'Probe Failure Alarm'	-	0	1	-	R
IS7	LOW_BATT	'Battery Alarm'	-	0	1	-	R

Tab. 6.b

For further information, see page 34

Key:

- HR = Holding register
- IR = Input register
- CS = Coil Status
- IS = Input Status

6.4 SI Sensor installation notes

1. Remove the cover by unscrewing the four screws at the front.
2. Fasten the case to the wall with minimum two screws, remembering that this is a radio device and therefore the necessary details must be observed.
3. Connect the two NTC temperature probes (10K@25°C Beta(25/85) = 3435K) to the terminals provided.
4. Connect the two digital inputs to the terminals provided (door and defrost).
5. Select the network address on the dipswitches.
6. Remove the insulating protection on the battery.
7. Perform the binding procedure.
8. Check the quality of the wireless signal; stimulate the sensor by pressing button T1 or activating magnetic switch SW1 and check the flashes on LED L3.
 - 1 flash, wireless connection with minimum signal strength;
 - 2 flashes, wireless connection with medium signal strength;
 - 3 flashes, wireless connection with excellent signal strength;
9. Close the sensor again.
10. Make sure that the transmitter is in an optimum position with reference to the receiver, once installation is complete, checking the transmitted signal level in the corresponding supervisor variable.



Fig. 6.e

6.5 Physical dimensions

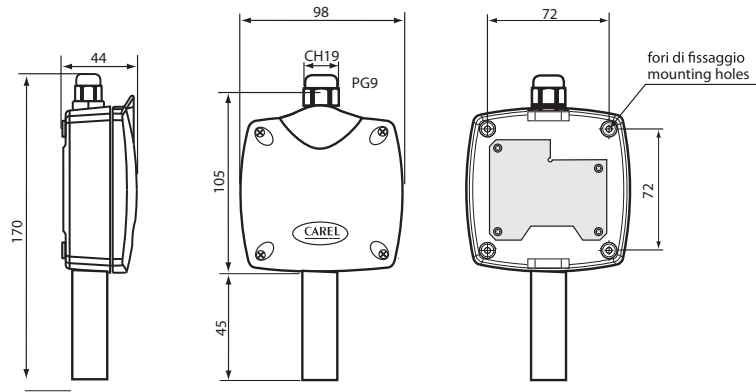

Fig. 6.f

6.6 Application example



Fig. 6.g

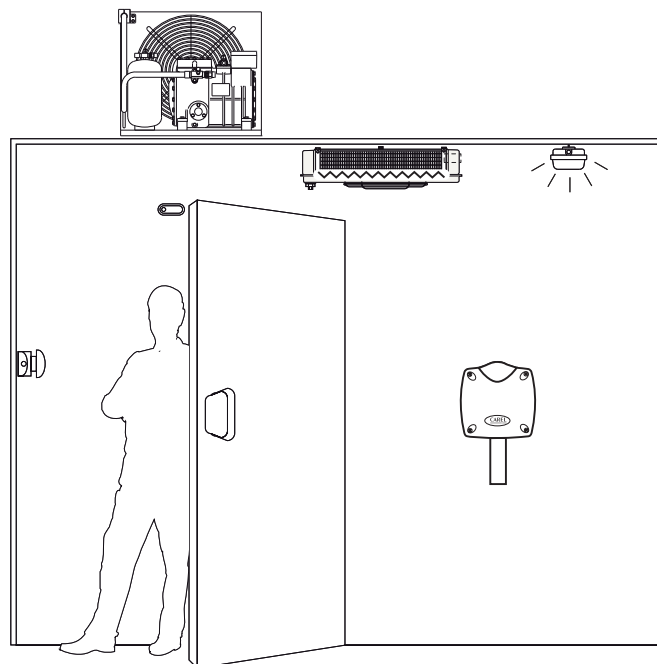

Fig. 6.h

7. CI PULSE COUNTER



Fig. 7.a

The pulse counter is a device used together with suitable energy meter modules to monitor power, gas and water consumption. It can manage two energy meters on the two digital inputs, and is fitted for connection of two external passive NTC temperature probes 10K@25°C (Beta(25/85) = 3435K). Closing the contacts on the digital inputs increases the value of two separate pulse counters.

7.1 Functions implemented

- Count pulses on ID1 (counter 1);
- Count pulses on ID2 (counter 2);
- Data transmission at settable interval in minutes (this affects battery life);

Main variables available to the supervisory system

- Impulse counter 1 value
- Impulse counter 2 value
- NTC temperature probe 1 in °C
- NTC temperature probe 2 in °C
- NTC 1 - NTC 2 temperature difference.
- Battery level in mV ;
- Wireless signal level in dBm +100 (8 = low signal, 15 to 30 = medium signal, greater than 30 excellent).
- Data transmission interval;
- TimeStamp for recording the instant measurement, expressed in hh:mm.

7.2 Parameters and functions

The device continuously and separately counts the pulses received on the two digital inputs, IN_1 and IN_2. The counter value is transmitted by the device at a frequency that depends on the transmission time parameter, according to the application and expected battery life. The counter value is saved in non-volatile memory every six hours of continuous device operation. Press the button on the sensor to send the sensor data manually, or check the connection.

Data transmission activation:

Wireless transmission is activated in the following conditions:

- Briefly pressing the button;
- In all other cases, data transmission is defined by the set transmission time.

Enable and disabling the analogue inputs

EN_NTC_1 and EN_NTC_2 enable and disable the probe inputs. The probe inputs can be enabled and disabled using parameters EN_NTC_1 and EN_NTC_2 respectively. If a probe input is disabled, the temperature reading is equal to 0°C; in this event, the probe alarm fault is not managed and remains constantly inactive (0).

By default the probe inputs are enabled.

Special commands – Command password

Special commands can be used to activate certain functions on the devices via the wireless network.

The commands are executed when parameter CS_00 is set to 1.

HR_00 (HEX)	HR_00 (DEC)	Action
0x01F5	501	Delete Pulse counter IN_1
0x01F6	502	Delete Pulse counter IN_2
0x01F7	503	Set Counter IN_1 to value in Password 2,3
0x01F8	504	Set Counter IN_2 to value in Password 2,3

Tab. 7.a

7.3 Technical specifications

Power supply	3.6V 2500 mAh lithium battery, "AA" size
Maximum power input	100 mW
Battery life in normal operating conditions	From 3 to 8 years, depending on the transmission time set (CAREL is not responsible for the specified battery life)
Radio frequency specifications	Frequency: selectable from 2405 to 2480 MHz Power transmitted: 0dBm Wireless protocol: ZigBee
Operating conditions	0T50°C, <80% RH non-condensing
Storage conditions	-20T70°C, <80% RH non-condensing
Range of temperature reading for NTC probes 1 and 2	-50T90°C, <80% RH non-condensing
Precision of temperature measurement	± 1 °C -10T30°C; ± 2 °C -30T40°C
Temperature measurement inputs	Measurement from -50 a + 90 C. Resolution 0.1 C. Compatible Power transmitted: 0dBm Wireless protocol: ZigBee
Digital inputs	For voltage-free contacts (isolated) - Closing current 0.01 mA. Use self-cleaning contacts, Open collector transistor or Reed Switch
MIN pulse duration	10 ms
MAX pulse frequency	20 Hz
Digital input current	700 µA
Connections - screw terminals for probes and digital inputs	Plug-in terminal step 3.81 cable size 0.5 mm2 (max 1.5 mm2)
Maximum connection length	Cable max length 10 m for probes and digital inputs
Index of protection against atmospheric agents	IP55 (see note 1)
Classification according to protection against electric shock	Can be integrated into class I or class II appliances
Environmental pollution	Normal
PTI of insulating materials	250 V
Period of stress across the insulating parts	Long
Category of resistance to heat and fire	category D (box and cover)
Immunity against voltage surges	category 1
Software class and structure	Class A
Disposal	observe local legislation for the disposal of electrical material
Product code	WS01E02M00 – Wireless pulse counter ver. CI battery powered 2NTC - 2DI -50 to 90°C
Accessories	WS00BAT000 - Battery, single package 0000000722 Magnet for activating SW1

Tab. 7.b

Note:

the index of protection is maintained only if a single cable is used for power and RS485 communication with an outside cross-section of less than 8 mm.

7.4 List of parameters and variables, CI Pulse Counter

Below is the table of supervisor parameters for the CI devices; this also applies to the RC Router-Pulse Counter (only for the special pulse counter function).

Modbus registers	Name	Description	Def.	Min	Max	UoM	"Type R/W"
HR0	CMD_PASSW_1	'Command Password (1)'	0	0	65535	-	R/W
HR1	TRANSM_CYCLE	'TX data cycle time'	60	5	3600	sec	R/W
HR2	CMD_PASSW_2	'Command Password (2)'	0	0	65535	-	R/W
HR3	CMD_PASSW_3	'Command Password (3)'	0	0	65535	-	R/W
HR4	INC_COUNTER	'Increase counter for input'	1	1	100	-	R/W
HR5	MIN_RSSI_LEVEL	'Minimum rssi level counted (internal use)'	0	0	99	-	R/W
HR6	CNT_REJOIN	'Max counter value before rejoin (internal use)'	30	1	255	-	R/W
IR0	MACHINE_CODE	'Unit type - machine code' (67=ZED, 68=ZR)	67/68	-	-	-	R
IR1	FW_VERSION	'Firmware version (Major/Minor)'	2051	-	-	-	R
IR2	TX_MESSAGE_CNT	'Total Number of TX radio messages'	0	0	65535	-	R
IR3	RX_MSG_LEVEL	'Radio signal Level'	0	0	100	dBm+100	R
IR4	BATTERY_LEVEL	'Battery Level'	-	0	3600	mV	R
IR5	PROBE_TMP_DIFF	'Temperature difference NTC1 probe - NTC2 probe'	-	-500	1000	0,1°C	R
IR6	TEMPERATURE_1	'Temperature Value probe 1'	-	-500	1000	0,1°C	R
IR7	TEMPERATURE_2	'Temperature Value probe 2'	-	-500	1000	0,1°C	R
IR8	IN_1_COUNTER_LOW	'Input Counter IN_1 (Low)'	0	0	65535	-	R
IR9	IN_1_COUNTER_HIG	'Input Counter IN_1 (High)'	0	0	65535	-	R
IR10	IN_2_COUNTER_LOW	'Input Counter IN_2 (Low)'	0	0	65535	-	R
IR11	IN_2_COUNTER_HIG	'Input Counter IN_2 (High)'	0	0	65535	-	R
IR12	IN_1_LAST_COUNT	'Input Counter IN_1 in last sampling period'	0	0	65535	-	R
IR13	IN_1_LAST_TIME	'Sampling period IN_1'	0	0	65535	sec	R
IR14	IN_2_LAST_COUNT	'Input Counter IN_2 in last sampling period'	0	0	65535	-	R
IR15	IN_2_LAST_TIME	'Sampling period IN_2'	0	0	65535	sec	R
IR16	MAC_ADDR_0	'Unit unique identifier Mac-Address LSB'	-	0	65535	-	R
IR17	MAC_ADDR_1	'Unit unique identifier Mac-Address MSB'	-	0	65535	-	R
IR18	ID_SER_ADDR	'Carel_ID, Serial_Address, DIP-SW value'	-	16	127	-	R
IR19	LAST_RX_DELAY	'Time from last AP Rx message'	-	0	65535	-	R
IR20	RX_MESSAGE_CNT	'Counter - AP Rx messages'	-	0	65535	-	R
IR21	TIME_STAMP	'Time stamp for Temp. readings (100*hour+minute)'	-	0	2359	hh*100+mm	R
IR22	AP_RX_RADIO_LEV	'Radio Lev. for AP Rx messages'	-	0	100	dBm+100	R
IR23	NETWORK_ID	'Network address'	-	0	65535	-	R
IR24	'MIRROR_IS'	'Mirror Input Status (internal use)'	-	0	65535	-	R
CS0	EN_CMD_PW	'Triq. PWD (internal use)'	0	0	1	-	R/W
CS1	EN_NTC_1	'Enable Probe NTC_1'	1	0	1	-	R/W
CS2	EN_NTC_2	'Enable Probe NTC_2'	1	0	1	-	R/W
IS0	IN_1_STATUS	'Digital Input State IN_1'	-	0	1	-	R
IS1	IN_2_STATUS	'Digital Input State IN_2'	-	0	1	-	R
IS2	PROBE_ERROR_1	'Probe 1 Failure Alarm'	-	0	1	-	R
IS3	PROBE_ERROR_2	'Probe 2 Failure Alarm'	-	0	1	-	R
IS4	ALM_GENERAL	'General Unit Alarm'	-	0	1	-	R
IS5	LOW_BATT	'Battery Alarm'	-	0	1	-	R

Tab. 7.c

For further information, see page 34

Key:

HR = Holding register

IR = Input register

CS = Coil Status

IS = Input Status

7.5 CI Pulse Counter installation notes

1. Remove the cover by unscrewing the four screws at the front.
2. Fasten the case to the wall with minimum two screws, remembering that this is a radio device and therefore the necessary details must be observed.
3. Connect the two NTC temperature probes (10K@25°C Beta(25/85) = 3435K) to the terminals provided.
4. Connect the two digital inputs to the terminals provided (door and defrost).
5. Select the network address on the dipswitches.
6. Remove the insulating protection on the battery.
7. Perform the binding procedure.
8. Check the quality of the wireless signal; stimulate the sensor by pressing button T1 or activating magnetic switch SW1 and check the flashes on LED L3:
 - 1 flash, wireless connection with minimum signal strength;
 - 2 flashes, wireless connection with medium signal strength;
 - 3 flashes, wireless connection with excellent signal strength;
9. Close the sensor again.
10. Make sure that the transmitter is in an optimum position with reference to the receiver, once installation is complete, checking the transmitted signal level in the corresponding supervisor variable.

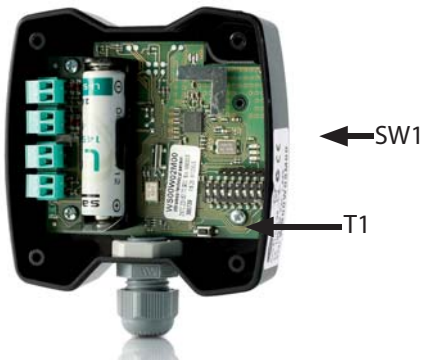

Fig. 7.b

7.6 CI Pulse Counter physical dimensions

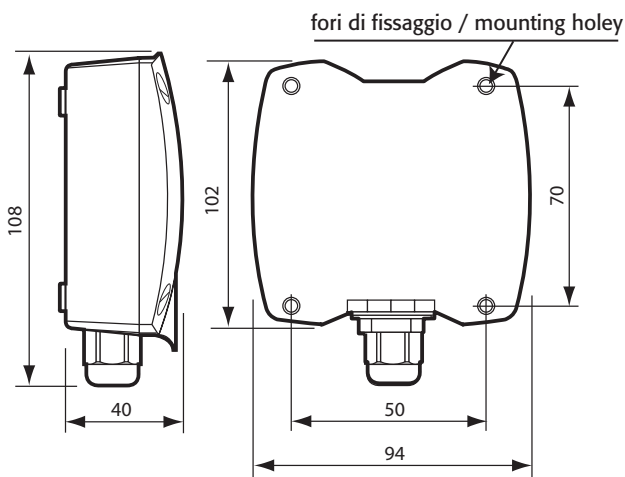

Fig. 7.c

7.7 CI Pulse Counter electrical connections

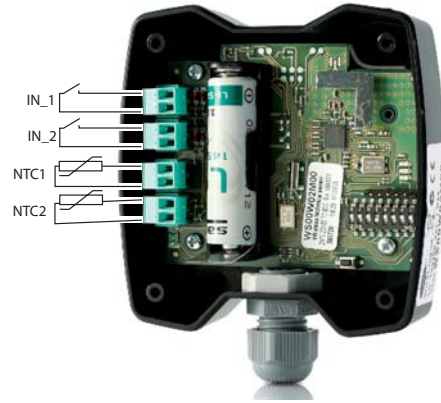

Fig. 7.d

1. Probe input NTC_1 10K@25°C Beta(25/85) = 3435K (e.g. NTC*HP* or NTC*WP*);
 2. Probe input NTC_2 10K@25°C Beta(25/85) = 3435K (e.g. NTC*HP* or NTC*WP*);
 3. Pulse counter digital input IN_1;
 4. Pulse counter digital input IN_2;
- The maximum cable length for NTC probes and digital inputs is 10 m

7.8 Connection example

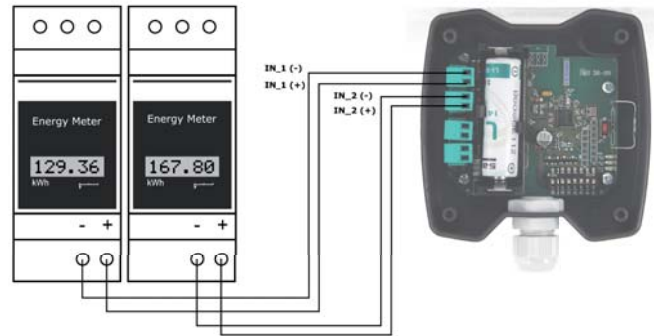

Fig. 7.e

8. AP ACCESS POINT



Fig. 8.a

This is the coordinator of a wireless network as well as the gateway for the information between the ZigBee™ protocol and the CAREL supervisor side (pCO, PlantVisor, PlantWatch or any CAREL master device). Up to 7 Access Points can be connected to the same serial line.

8.1 Main functions

- Manual opening/closing of the wireless domain (button). Via software or rTM SE handheld for binding the devices (sensors or Routers);
- Automatic selection of the channel wireless to be used.
- Count the number of sensors connected;

8.2 Parameters and functions

The Access Point manages the wireless network and the wireless connection of all the units, making these accessible to the supervisory system via the Modbus RS485 serial connection.

For all the sensors managed directly, it stores a copy of all the parameters and variables, which are updated every time data is transmitted via the wireless connection.

The Access Point makes the data for all the peripherals available to the supervisor at all times, even if wireless transmission is performed at set intervals.

Setting the operating mode

Parameter HR_03 used to set the Access Point operating mode.

The table below summarises the various operating modes:

Value	Description	Notes
HR_03 = 21	Communication with Router-Bridge disabled	(default)
HR_03 = 17	Communication with Router-Bridge enabled	Filters should be configured to set the min and max addresses of the devices connected via Router-Bridge (HR_11 and HR_12);

8.3 Configuration

The following chapter describes the procedure for setting the address, configuration and connection of the devices, so as to create a wireless domain that is connectable to a controller via the Modbus RTU protocol.

A fundamental step is commissioning, which involves the unique identification of each device by:

- Assigning a unique network address to each device;
- Binding of the devices to a domain so that the devices can communicate with each other. All the other devices cannot communicate even if they are reached by the wireless signal.

Security of communication over the network is guaranteed by the 128 bit encryption key (AES) written inside the program on each device.

In normal operation, only the serial address is used, which is also unique within the network and is sufficient to identify each unit.

WARNING!

Two units cannot have the same serial address. Therefore pay careful attention when assigning the network addresses to the sensors and Access Points so that there are no devices with the same serial address, also considering any instruments connected to the remote wired network via the Bridge. This would create conflicts and interference in the storing of temperature data.

8.4 Setting the address

This is a fundamental phase in setting up the system, and allows each device to be identified uniquely by assigning a unique network address to each device (Modbus® network address).

Access Point

- Assign the CAREL network address and baud rate using 4 dipperswitches as shown in the following table;
- Power up the Access Point;
- Check that the LED 1 is always on and the others are off. If the LEDs are not in this status, reset the Access Point (see Resetting the devices).

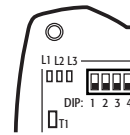

DIP 1-2-3 network address selection

DIP 4 baud of network selection

Fig. 8.b

Important: the address can be changed after switching off/on.

Dipswitch				Access Point address	Serial port baud rate (Bit/S) N82
1	2	3	4		
OFF	OFF	OFF	OFF	0 (settable from the supervisor)	9600
ON	OFF	OFF	OFF	1	9600
OFF	ON	OFF	OFF	2	9600
ON	ON	OFF	OFF	3	9600
OFF	OFF	ON	OFF	4	9600
ON	OFF	ON	OFF	5	9600
OFF	ON	ON	OFF	6	9600
ON	ON	ON	OFF	7	9600
OFF	OFF	OFF	ON	0 (settable from the supervisor)	19200
ON	OFF	OFF	ON	1	19200
OFF	ON	OFF	ON	2	19200
ON	ON	OFF	ON	3	19200
OFF	OFF	ON	ON	4	19200
ON	OFF	ON	ON	5	19200
OFF	ON	ON	ON	6	19200
ON	ON	ON	ON	7	19200

Tab. 8.a

Creating the network and selecting the wireless communication channel

The wireless system requires of use a transmission channel for the communication of the wireless messages between the various devices.

The best communication channel for the environment in question is automatically selected by the Access Point, using the following procedure:

Power up the Access Point (LED 1 must be on steady);



Press the button and check the activation sequence:



For 10s: LED 1 and 2 on



For 30s: LED 2 on (search for ZigBee channel)



LED 1 flashes slowly (1s).

The Access Point is ready for use, the wireless network has been initialised. The transmission channel has been selected and will be sent to the Routers and sensors during the binding phase.

Important:

- If the sequence does not occur as indicated, reset the device (see Resetting the device);
- If the Access Point is reset, all the instruments bound to it will be disconnected and will need to be bound again.

8.5 Binding procedure

The logical connection between the Access Point and the wireless devices is called binding. This operation must be performed after setting the addresses and selecting the communication channel.

Power up the Access Point and check that LED 1 flashes slowly (1s).



(In the drawing LED 1 is shown flashing slowly).

OPEN DOMAIN: press button T1. LED 1 flashes quickly (around 0.25s)



(In the drawing LED 1 is flashing quickly).

In this phase, new devices can be bound.

CLOSE DOMAIN: After having connected all the devices, press the button to close the domain (LED 1 starts flashing slowly again, around 1s).



(In the drawing LED 1 is flashing slowly).

NOTE: The domain closes automatically 15 minutes after last opening. The domain can be opened/closed on the Access Point from the Modbus controller, using the following procedure, checking the status using parameters IS_00, IS_01:

		Modbus® variables indices
• OPEN DOMAIN:	Select	➔ HR_00=5266
	Enable command	➔ CS_00 = 1
• CLOSE DOMAIN:	Select	➔ HR_00=5267
	Enable command	➔ CS_00 = 1
• Network domain status:	Network open,	➔ IS_01 = 1
	Binding active	➔ IS_01 = 0
	Network closed	
• Access Point with Network Active:	Network initialised	➔ IS_00 = 1
	Network NOT initialised	➔ IS_00 = 0

Tab. 8.b

The wireless network can also be opened or closed from the rTM SE handheld. For further information, see the specific chapter further on.

8.6 Resetting the device

To reset the device, proceed as follows:

Press and hold button T1 (L1 flashes quickly)

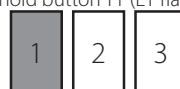

after 10s L3 comes on for 4 to 5s



Release button T1 when LED L1 remains on steady.



Wait until the 3 LEDs flash together 3 times and then switch off.



Flash quickly

When L1 remains on steady the device has been reset.

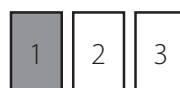

Note: all devices previously bound will be removed from the Access Point/ Router (no. devices connected=0).

8.7 Serial communication parameters

The Access Point data and the data of all the devices making up the network can be accessed via ModBus-RTU serial communication protocol. The serial communication parameters are as follows:

- Speed:** 9600 Bps (DIP4=off) / 19200Bps (DIP4=on)
- Data bits:** 8
- Parity:** None
- Stop bits:** 2
- Flow control:** None

Given the nature of the Modbus protocol, the data for all the devices, including the l'Access Point, are divided into four memory areas:

- IRxx ➔ **InputRegister** (16 bit read-only variables)
- ISxx ➔ **InputStatus** (1 bit read-only variables)
- HRxx ➔ **HoldingRegister** (16 bit variables, generally non-volatile)
- CSxx ➔ **CoilStatus** (1 bit variables)

The codes of the functions implemented in the Access Point are as follows:

- 01 - READ COIL STATUS
- 02 - READ INPUT STATUS
- 03 - READ HOLDING REGISTER
- 04 - READ INPUT REGISTER
- 05 - FORCE SINGLE COIL
- 06 - PRESET SINGLE

8.8 Table of LED status

Action	LED sequence (with times in sec.)	Meaning of the signal
---	L1 ON	Access Point ON with wireless channel not configured
Press button T1 (first time)	L1 and L2 ON (10s) L2 ON (30s) L1 flashing slowly (1s)	Select wireless channel PANID and extended PANID automatically
---	L1 flashing slowly (1s)	Access Point ON with wireless channel configured
---	L3	Normally off. On when sending or receiving a wireless message
Press button T1 to open wireless network	L1 flashing quickly (0.25s)	Access Point with the wireless network open (ready for binding the devices)
Press and hold button T1	L1, flashing quickly L3 on for 2s L1 on steady Release button T1 L1, L2, L3 flash quickly and at the same time several times L1 on steady (end of the procedure)	Reset without disconnecting power
---	L2 Router with a good connection in the vicinity	Off → No Router with good connection in the vicinity flash → Router with good connection in the vicinity flashes → two Routers with good connection in the vicinity flashes → four or more Routers with good connection in the vicinity

Tab. 8.c

The table describing the LEDs does not refer to normal operation of the Access Point, but rather the procedure for defining the network, an operation performed only during configuration. The last row only describes the behaviour of the LED (L2 only) during the “normal” operation of the device.

8.9 Technical specifications

Power supply	12-24 Vac/dc ±10% 100mA; 50/60 Hz; Use a class II safety transformer with minimum power rating of 2 VA. 12 Vac transformer recommended
Maximum power input	1 VA
Radio frequency specifications	Frequency: selectable from 2405 to 2480 MHz (by parameter or automatically, see the table of supervisor parameters) Power transmitted: 0dBm Wireless protocol: ZigBee
RS485 transmission speed	9600/19200 b/s
Max. num. of sensors that can be bound	30 sensors (60 by adding a Router) 16 Routers
Operating conditions	0T50°C, <80% RH non-condensing
Storage conditions	-20T70°C, <80% RH non-condensing
Connections - screw terminals for power supply	-Power supply terminal: plug-in cables max size 1.5 mm ² - RS485 communication terminal: plug-in cables max size 1.5 mm ² (use shielded cable with shield connected to GND) - RS485 communication terminal: plug-in cables max size 1.5 mm ² (use shielded cable with shield connected to GND)
Type of cable	Shielded cable max length 1000 m (RS485), 100 m (Power supply)
Assembly	wall-mounted by screws
Display/Configuration Protocol	Read and write parameters via RS485 RS485 Modbus RTU
Index of protection	IP55 (see note)
Classification according to protection against electric shock	Can be integrated into class I or class II appliances
Environmental pollution	Normal
PTI of insulating materials	250 V
Period of stress across the insulating parts	Long
Category of resistance to heat and fire	category D (box and cover)
Immunity against voltage surges	category 2
Software class and structure	Class A
Disposal	observe local legislation for the disposal of electrical material
Product code	WS01AB2M20 - Access Point 12-24 Vac/dc
Accessories	TRASP3E120 – Plug-in transformer 3VA 230-12Vac TRADR4W012 Panel transformer 3VA 230-12Vac

Tab. 8.d

Note:

1. The index of protection is maintained only if a single cable is used for power and RS485 communication with an outside cross-section of less than 8 mm.
2. It's recommended to use an external junction box for creating the connections and fitting the transformer.

8.10 List of Access Point system variables (alphabetical order)

AP_ALTER_ADDR	Alternative address of the Access Point (used if dipswitch=0) default=1. Used to set an alternative address to the on set by dipswitch (make sure to avoid network conflicts); The new address must be set for parameter AP_ALTER_ADDR (HR_10);
AP_CONN	Indicates whether the Access Point is managing the wireless network (1 = yes);
AP_OPEN	Indicates that the network is open and new devices can be bound (1 = yes);
AP_RESET_CNT	Wireless network verification parameters for internal use;
AP_RESET_TYPE	Wireless network verification parameters for internal use;
AP_TX_RADIO_LEV	Indicates the wireless transmission and reception levels for the Access Point in dBm +100. For minimum reception, the value must be greater than 8, medium quality reception from 15 to 30, and good quality values greater than 30;
CMD_PASSW_1...7	Commands used to configure the wireless network. Used by installation and configuration tools;
CONN_AP	Number of units directly connected to the Access Point;
CONN_BINDED	Total number of units visible in the network from the remote wired network Bridge (see Bridge);
CONNECTED_UNIT	Total number of sensors connected to the wireless network and managed by Access Point;
EN_CMD_PW	Commands used to configure the wireless network. Used by installation and configuration tools;
FREE_BUFFER	Wireless network verification parameters for internal use;
FW_VERSION	Access Point FW revision
ID_SER_ADDR	Serial address value, set by dipswitch. Can be used as the unit identifier;
MAC_ADDR_0	Unique 32 bit unit identifier (0 = LSB), used to uniquely identify each unit;
MAC_ADDR_1	Unique 32 bit unit identifier (1 = MSB), used to uniquely identify each unit;
MACHINE_CODE	Peripheral identifier for the supervisor (112 for the Access Point);
MAX_SELEC_ADDR	Maximum address value allowed for devices behind the Router-Bridge, default=247
MIN_SELEC_ADDR	Minimum address value allowed for devices behind the Router-Bridge, default=1
NET_CHANNEL	ZigBee Network transmission channel. Uniquely defines the wireless network used by the system for communication (Access Point, Repeaters, Sensors). The value is set during the configuration procedure or using the commissioning tool;
NET_PANID	ZigBee network transmission identifier. Uniquely defines the wireless network used by the system for communication (Access Point, Repeaters, Sensors). The value is set during the configuration procedure or using the commissioning tool;
NET_PANID_EXT_0...3	Network Extended PanID Network identifiers. Guarantee greater security on the wireless network. Fundamental parameters for cloning the ZigBee network
OFFLINE_MODE	Access Point response mode for units that are Offline. Parameter HR_03 (Operating mode, default value 21; HR_03 = 21 Communication with Router-Bridge disabled (default); HR_03 = 17 Communication with Router-Bridge enabled. Filters should be configured to set the min and max addresses of the devices connected via Router-Bridge (HR_11 and HR_12); Note: a peripheral is considered Offline by the Access Point after 4 query cycles, i.e. after a time of 4 x TRANSM_CYCLE..
RES_COUNTER	Wireless network verification parameters for internal use;
ROUTER_CONN_NEARBY	Number of Routers in the vicinity;
ROUTER_CONNECTED	Total number of routers connected to the network;
ROUTER_GOOD_SIGNAL	Number of Routers in the vicinity with a good wireless signal, ≥ 30 dB;
ROUTER_TX_TIME	Transmission time for wireless refresh signal (aggregation)

RX_MSG_LEVEL	Indicates the wireless transmission and reception levels for the Access Point in dBm +100. For minimum reception, the value must be greater than 8, medium quality reception from 15 to 30, and good quality values greater than 30;
RX_MSG_LEVEL	Wireless network verification parameters for internal use;
TIME_STAMP	Clock in hours:minutes for recording the times the sensors measure and send data. This is updated/ incremented every minute by the Access Point, the value can be set from the supervisor to align it with a real clock. Invalid values are rounded off to the nearest (hour: minutes). The value is lost in the event of power failures, restarting from 00:00. If synchronisation is required, the supervisor must reset the value;

Tab. 8.e

Note:

the parameters described are divided into 4 groups based on the Modbus standard:

- HR_xx Read/write registers (16-bit word)
- IR_xx Read-only registers (16-bit word)
- CS_xx Read/write bits (1-bit)
- IS_xx Read-only bit (1-bit)

Parameters specified as: "Configuration" or "Verify NETWORK" are not normally used in the supervisor application. They can on the other hand be used by configuration systems (commissioning tool).

8.11 List of parameters and variables, Access Point versione Modbus® RTU

In order to access the information from the system of sensors, the supervisor connection settings are as follows:

Modbus® RTU protocol;

baud rate 9600 8, N, 2 or 19200 8, N, 2. Below is the table of supervisor variables for the system components.

Modbus registers	Name	Description	Def.	Min	Max	UoM	"Type R/W"
HR0	'CMD_PASSW_1'	'Command Password (1)'	0	0	65535	-	R/W
HR1	'CMD_PASSW_2'	'Command Password (2)'	0	0	65535	-	R/W
HR2	'CMD_PASSW_3'	'Command Password (3)'	0	0	65535	-	R/W
HR3	'OFFLINE_MODE'	'Mode Status Access-Point'	21	1	63	-	R/W
HR4	'TIME_STAMP'	'Clock Counter as hh:mm for RX-data TimeStamp'	0	0	2359	hh*100+mm	R/W
HR5	'ROUTER_TX_TIME'	'Sending time to find new ways (default 20sec)'	20	10	60	sec	R/W
HR6	'CMD_PASSW_4'	'Command Password (4)'	0	0	65535	-	R/W
HR7	'CMD_PASSW_5'	'Command Password (5)'	0	0	65535	-	R/W
HR8	'CMD_PASSW_6'	'Command Password (6)'	0	0	65535	-	R/W
HR9	'CMD_PASSW_7'	'Command Password (7)'	0	0	65535	-	R/W
HR10	'AP_ALTER_ADDR'	'Gateway Alternative Address (used if DipSwitch=0 default=1)'	1	1	247	-	R/W
HR11	'MIN_SELEC_ADDR'	'Minimum address allowed for devices behind Router Bridge (default=1)'	1	1	247	-	R/W
HR12	'MAX_SELEC_ADDR'	'Maximum address allowed for devices behind Router Bridge (default=247)'	247	1	247	-	R/W
IR0	'MACHINE_CODE'	'Unit type - machine code'	112	-	-	-	R
IR1	'FW_VERSION'	'Firmware version (Major/Minor)'	2051	-	-	-	R
IR2	'AP_TX_RADIO_LEV'	'AccessPoint Trasmission Power'	99	-	-	dBm+100	R
IR3	'NET_CHANNEL'	'Network Channel - ZigBee'	0	0	26	-	R
IR4	'NET_PANID'	'Network PanId'	0	0	65535	-	R
IR5	'RES_COUNTER'	'Counter - seconds from last Reset'	0	0	65535	sec	R
IR6	'RX_MESSAGE_CNT'	'Counter - Rx messages from last Reset'	0	0	65535	-	R
IR7	'CONNECTED_UNIT'	'Number of connected units (On-line units) end-Devices'	0	0	112	-	R
IR8	'ID_SER_ADDR'	'Carel_ID, Serial_Address, DIP-SW value'	-	1	247	-	R
IR9	'MAC_ADDR_0'	'Units unique identifier Mac-Address LSB'	-	0	65535	-	R
IR10	'MAC_ADDR_1'	'Units unique identifier Mac-Address MSB'	-	0	65535	-	R
IR11	'RX_MSG_LEVEL'	'Radio signal Level'	0	0	100	dBm+100	R
IR12	'CONN_BINDED'	'Number of units connected through Router Bridge (Remote Wired Network)'	0	0	255	-	R
IR13	'CONN_AP'	'Number of units connected to AccessPoint'	0	0	32	-	R
IR14	'AP_RESET_CNT'	'Counter - Reset number for AccessPoint'	0	0	65535	-	R
IR15	'AP_RESET_TYPE'	'Type for AccessPoint Reset'	-	0	255	-	R
IR16	'FREE_BUFFER'	'Free Packet-Buffer (available connection slot)'	-	0	255	-	R
IR17	'NET_PANID_EXT_3'	'Network PanId Extended MSB'	0	0	65535	-	R
IR18	'NET_PANID_EXT_2'	'Network PanId Extended'	0	0	65535	-	R
IR19	'NET_PANID_EXT_1'	'Network PanId Extended'	0	0	65535	-	R
IR20	'NET_PANID_EXT_0'	'Network PanId Extended LSB'	0	0	65535	-	R
IR21	'ROUTER_CONNECTED'	'Number of Routers in the network'	0	0	65535	-	R
IR22	'ROUTER_CONN_NEARBY'	'Number of Router nearby'	0	0	16	-	R
IR23	'ROUTER_GOOD_SIGNAL'	'Number of Router nearby with good connection'	0	0	16	-	R
CS0	'EN_CMD_PW'	'Enable Command Password (internal use)'	0	0	1	-	R/W
IS0	'AP_CONN'	'AccessPoint connected to Radio Network (1=Yes)'	0	0	1	-	R
IS1	'AP_OPEN'	'AccessPoint Network Open/Closed (1=open)'	0	0	1	-	R

Tab. 8.f

For further information, see page 34

Legend:

HR = Holding register

IR = Input register

CS = Coil Status

IS = Input Status

8.12 Installation notes

- Fasten the Access Point to the wall with the cable gland facing downwards;
- Connect the RS485 network to the terminal respecting the polarity;
- Tighten the antenna in the special housing, and position it vertically to the floor;
- Connect the 12-24 Vac power supply to the terminal, ensuring the polarity indicated for DC power supply. A 12 Vac transformer is recommended.
- For correct operation the system must be powered at all times, in the event of power failures there may be a unit reset time (OFFLINE) based on the data transmission cycle.

IMPORTANT: if the same power supply is shared by more than one unit, connect the same wire from the transformer to the power supply "-" terminal.

8.13 Electrical connections and physical dimensions

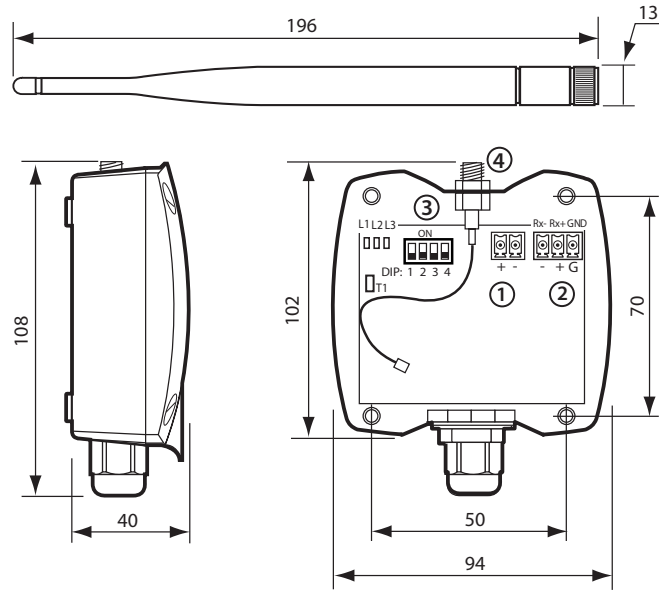

Fig. 8.c

Note: all the measurements are in mm.

9. RO ROUTER



Fig. 9.a

This is a device that repeats the wireless signals so as to cover greater distances between the Access Point and the sensors. As soon as it detects a wireless signal recognised by the network, it relays it. In addition, it can be used to expand the number of sensors connected to the Access Point when these exceed 30 units, or if the distance is greater than 30 m.

9.1 Parameters and functions

For each Router in the network, the information listed in the table can be identified from the notification messages sent by the Router to the Access Point, updated at intervals established by parameter HR_05 on the Access Point (default 20s).

9.2 Binding the Router to the Access Point

- Open the domain on the Access Point (press button T1 once).
- Power up the Router.
- The button on the Router does not need to be pressed, if the device is free the procedure is activated automatically.
- All the LEDs come on steady.
- The Router searches for an Access Point to connect to (all the LEDs flash every 20s).
- Binding is successfully completed when only LED L1 remains on flashing, the Router is now connected to the Access Point.
- The Router address is set automatically and sequentially by the Access Point when it's added to the network, assigning the network addresses from 200 to 247 for a maximum of 48 devices. This is valid for all Routers (including the Router-Bridge and EP1 Router-Sensor, etc.). A maximum of 60 Routers can be added.
- The commissioning procedure is now complete and the system is ready to communicate data.

Adr #200	Slot 1st Router added to the network
Adr #201	Slot 2nd Router added to the network
Adr #202	Slot 3rd Router added to the network
Adr #203	Slot 4th Router added to the network
Adr #204	Slot 5th Router added to the network
Adr #200+(i-1)	Slot i-th Router added to the network
Adr #247	Slot 48th Router added to the network

Tab. 9.a

NOTE: the binding operation on the Router may fail if:

- Distances are excessive;
- Infrastructure is present that prevents communication between the devices;

Each sensor installed should be visible to at least 2 devices, either Access Point or Router. In the event of faults on the Router or additional barriers that block the wireless signal, the sensor will find an alternative route to communicate with the Access Point.

Table of alternative addresses associated with the Router

Check the settings on the Access Point described in the chapter "Setting operating mode"

InputRegister[1000] - InputRegister[1011]	Slot 1st Router added to the network
InputRegister[1012] - InputRegister[1023]	Slot 2nd Router added to the network
InputRegister[1024] - InputRegister[1035]	Slot 3rd Router added to the network
InputRegister[1036] - InputRegister[1047]	Slot 4th Router added to the network
InputRegister[1048] - InputRegister[1059]	Slot 5th Router added to the network
InputRegister[1000+12*(i-1)] - InputRegister[1011+12*(i-1)]	Slot i-th Router added to the network
InputRegister[2524] - InputRegister[2535]	Slot 128th Router added to the network
InputRegister[...0]	Entry status (0xFF=slot empty; 0=Router timeout; 1=Router on)

Tab. 9.b

Router information table

InputRegister[...1]	Type of device (e.g.: 101=Router ZR-BR-xx; 108=Router ZR-REP-xx)
InputRegister[...2]	Firmware version
InputRegister[...3]	Router EUI64 (bytes 0, 1)
InputRegister[...4]	Router EUI64 (bytes 2, 3)
InputRegister[...5]	Router ShortID
InputRegister[...6]	Cost (distance from the Gateway in terms of hops)
InputRegister[...7]	RSSI of the last message received by the Router (db+100)
InputRegister[...8]	Number of Routers
InputRegister[...9]	Number of "good" Router neighbours
InputRegister[...10]	Number of Router End-Device children
InputRegister[...11]	Counter of presence messages sent by the Router and received by the Gateway

Tab. 9.c

Make sure that the serial address associated automatically and sequentially is not in conflict with another device already associated with the network.

Binding the Routers

OPEN DOMAIN: press button T1 on the Access Point. LED L1 will start flashing quickly (0.25s).

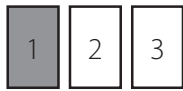

New devices can now be added;

Power up the Router and wait for LED L1 to flash;

CLOSE DOMAIN: After having added all the required devices, press button T1 on the Access Point to close the domain (LED L1 starts flashing again (1s) on the Router and the Access Point.



NOTE: The domain closes automatically 15 minutes after last opening;

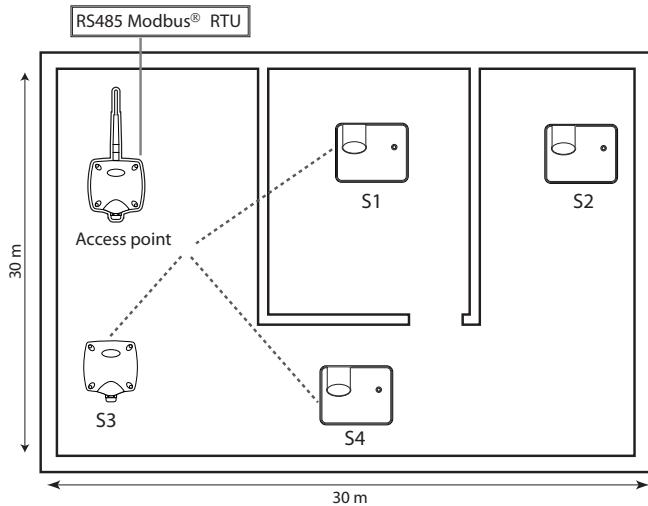

Fig. 9.b

9.3 Resetting the device

To reset the device, proceed as follows..

Make sure that there are no Access Points with the network open in the vicinity. Press and hold button T1 until the pairs of LEDs L1-L2 and L2-L3 flash alternately.



Release the button. LEDs L1, L2 and L3 will flash briefly a few times and all three switch off (reset completed).

Warning!!!

Resetting the Router does not reset the serial address assigned automatically by the Access Point if connected again to the same AP within 2 hours. If bound to another network, it behaves like a new Router and consequently the first available address will be assigned (if previously reset).

9.4 Table of LED status

LEDs in normal operation	Action	Meaning of the signal
LED L1	Operation	slow flash (1Hz) network Access Point closed quick flash (4Hz) network Access Point open
LED L2	Wireless link	off → No Router with good connection in the vicinity 1. flash → Router with good connection in the vicinity 2. flashes → two Routers with good connection in the vicinity 3. flashes → four or more Routers with good connection in the vicinity
LED L3	Wireless activity	1. Normally off. 2. On when sending or receiving a wireless message.

Tab. 9.d

10. ROUTERS WITH OTHER INTEGRATED FUNCTIONS

Other Router devices are available that integrate the following functions:

- EP1 Router-Sensor (with two analogue and two digital inputs, the same operation as the EP SE Sensor battery version);
- RB Router-Bridge (to extend a Modbus RS485 local network, connecting other devices);
- RA Router-Actuator (I/O module with thermostat function);
- RC Router-Pulse Counter (same operation as the CI Pulse Counter battery version);

The address setting and reset procedures as the same as described for the Router.

The dialswitches on the device are used to set the address for the integrated functions. Consequently each device has two network addresses: the Router address assigned automatically by the Access Point, and the device address selected by dialswitch (excluding the Router-Bridge). For complete supervision of the devices, both network addresses must be monitored;

10.1 EP1 Router-Sensor

The EP1 Router-Sensor has 2 probe inputs and 2 digital inputs, and features the same functions and same parameters as the EP SE Sensor battery version. It is used in all applications requiring monitoring of digital inputs that change frequently and where the life of the battery version would be too short (each opening and closing of the digital contact causes wireless communication to update the parameters).

For the features, operating modes and supervision, see this manual under the section on the EP SE Sensor.

10.2 RB Router-Bridge

The Router-Bridge is used to connect a local Modbus RTU network of Carel or third party devices when needing to supervise instruments via a wireless network. The address setting and reset procedures are the same as described for the Router.

The following approved devices can be connected to the local network::

- Gavazzi CPT-DIN / WM14;
- Gavazzi WM14;
- IR33 Modbus® IR33COHB0M.

The devices described above have been checked with the PVPRO supervisor as shown below. Operation of the devices outside of the limits indicated or with others supervisors is not guaranteed.

1. **Limits in message sizes.** Responses must not exceed 52 bytes; this implies that no more than 26 registers (holding registers or input registers) can be read with one single message;
2. **Query frequency.** The time interval between receiving a response and the following query must not be less than one second;
3. **Communication timeout.** The time interval between two consecutive queries before a response is received must not be less than 3 seconds. This means a communication timeout of at least 3 seconds.

Dipswitches 1 to 4 are used to set the operating features of the local Modbus RS485 serial connection.

DIP1	DIP2	DIP3	DIP4	Speed	Parity	Stop Bits
OFF	OFF	OFF	OFF	9600	none	2
ON	OFF	OFF	OFF	19200	none	2
OFF	ON	OFF	OFF	9600	even	2
ON	ON	OFF	OFF	19200	even	2
OFF	OFF	ON	OFF	9600	none	2
ON	OFF	ON	OFF	19200	none	2
OFF	ON	ON	OFF	9600	odd	2
ON	ON	ON	OFF	19200	odd	2
OFF	OFF	OFF	ON	9600	none	1
ON	OFF	OFF	ON	19200	none	1
OFF	ON	OFF	ON	9600	even	1
ON	ON	OFF	ON	19200	even	1
OFF	OFF	ON	ON	9600	none	1
ON	OFF	ON	ON	19200	none	1
OFF	ON	ON	ON	9600	odd	1
ON	ON	ON	ON	19200	odd	1

Tab. 10.a

- Limits for correct serial communication management:
- Message size max 52 bytes.
- Query frequency min 1 second
- Communication timeout min 3 seconds

Installation example of the Router-Bridge and EP1 Router-Sensor in a network with other wireless devices

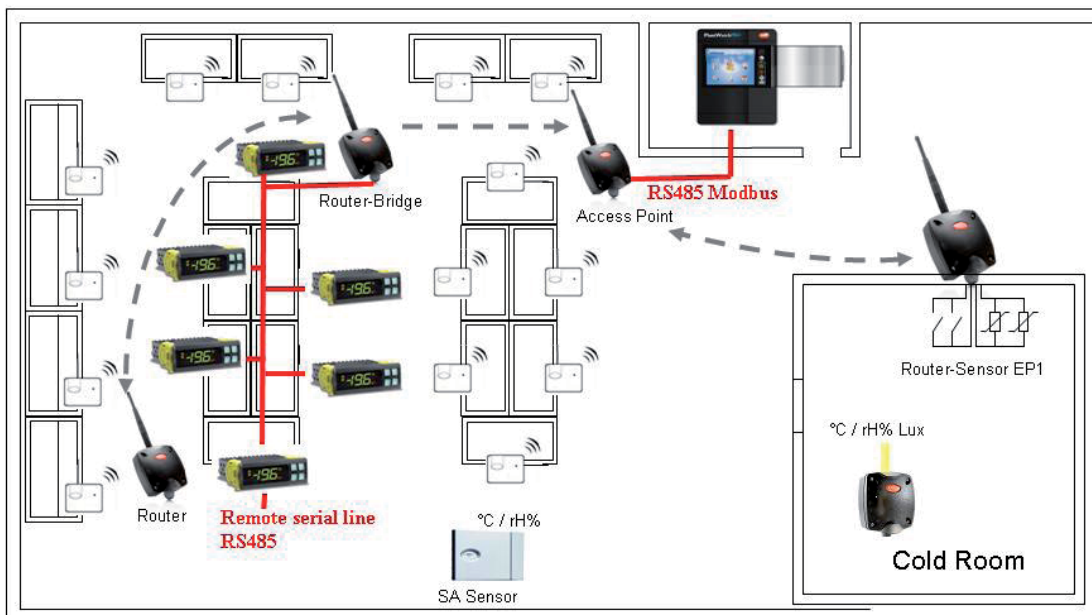

Fig. 10.a

10.3 RA Router-Actuator

The Router-Actuator is a device featuring:

- 1 NTC probe input 10K@25°C
- 2 two digital inputs;
- 2 digital outputs;

The device implements a thermostat function with programmable heating/cooling mode, relay outputs and alarm management based on set thresholds. Alternatively, the control function can be disabled and inputs and outputs managed directly by the supervisor or via Modbus® controller.

10.4 Functions implemented

Analogue temperature input management

The device acquires the temperature via the analogue input using an external probe with sampling once a second (probe 10K@25°C Beta=3435K). The operating range is -50T90°C. When the temperature values are outside of these limits, the device signals an alarm:

- +100 → probe input short-circuited;
- -50 → probe input open;

Temperature alarm management

The device compares the temperature measured by the reference probe against the parameters that define the alarm limits. There are no delays in activating the alarm signal; as soon as the acquired value is higher than the maximum limit or lower than the minimum limit the alarm is activated.

- If Temperature > High temperature limit → high temp. alarm =1
- If Temperature ≤ High temperature limit → high temp. alarm =0
- If Temperature < Low temperature limit → low temp. alarm =1
- If Temperature ≥ Low temperature limit → low temp. alarm =0

If the probe input is short-circuited (signal equal to +100.0°C), as well as the probe fault alarm, the high temperature alarm is also activated.

If the probe input is open (signal equal to -50.0°C), as well as the probe fault alarm, the low temperature alarm is also activated.

Control management (digital outputs)

The control process is managed based on the Control mode parameter.

Mode =0

Control is disabled and both relays are deactivated.

Mode =1 (Cool)

Control is performed as follows:

- High threshold = Set Point + Hysteresis/2
- Low threshold = Set Point - Hysteresis/2

- If Temperature > High threshold → Relay 1 On ; Relay 2 Off
- If Temperature < Low threshold → Relay 1 Off ; Relay 2 On

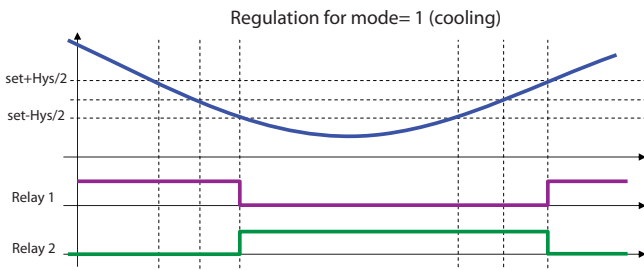

Fig. 10.b

Mode =1/2 (Cool/heat) - Relay 1 management in the event of probe fault

In the event of a probe fault, control is disabled and Relay 1 is deactivated.

Mode =1/2 (Cool/heat) - Relay 2 management

Relay 2 is controlled by variable SET_RELE2.

If the device does not detect the Access Point for more than a minute, it switches to Off-Line.

In this mode, Relay 2 is controlled automatically with on/off cycles managed by the following parameters:

DEF_TIME → Defrost duration, expressed in minutes, default = 10 minutes

DEF_INTER → Defrost interval, expressed in hours, default = 8 hours

The times corresponding to these parameters refer to the instant the Relay 2 is activated, whether this is controlled by SET_RELE2 or automatically activated when Off-Line.

Case 1: Offline when Relay 2 inactive

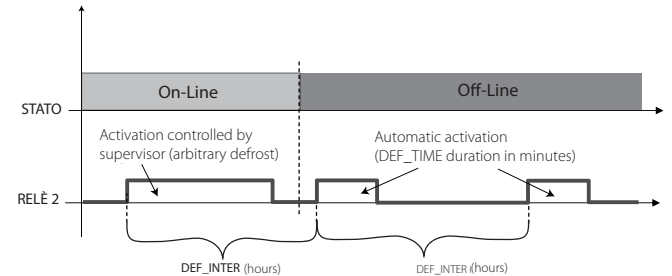

Fig. 10.c

Case 2: Offline when Relay 2 active

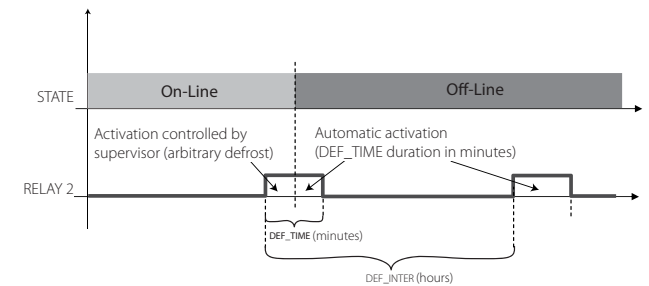

Fig. 10.d

Behaviour of Relay 2 on reset: the device saves the state of the defrost relay to non-volatile memory, consequently an off/on cycle does not change state.

Case 3: Off when Relay 2 inactive and Off-line at power on

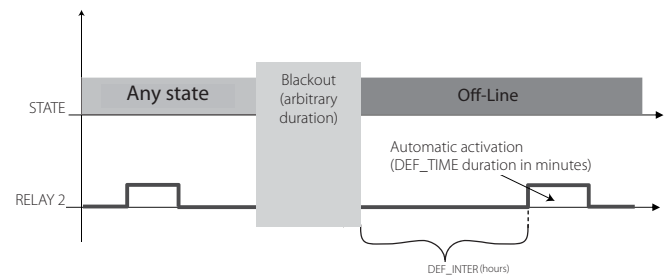

Fig. 10.e

Case 4: Off when Relay 2 active and Off-line at power on

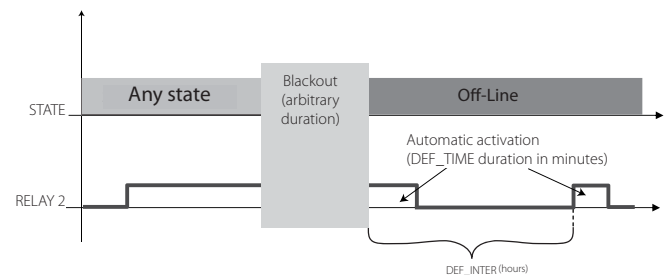

Fig. 10.f

Note: starting from firmware version 2053, the activation of Relay 2 (defrost relay) causes the consequent deactivation of Relay 1 (control relay).

Mode =2 (Heat)

Control is performed as follows:
 High threshold = Set Point + Hysteresis/2
 Low threshold = Set Point - Hysteresis/2

If Temperature > High threshold --> Relay 1 Off ; Relay 2 On
 If Temperature < Low threshold --> Relay 1 On ; Relay 2 Off

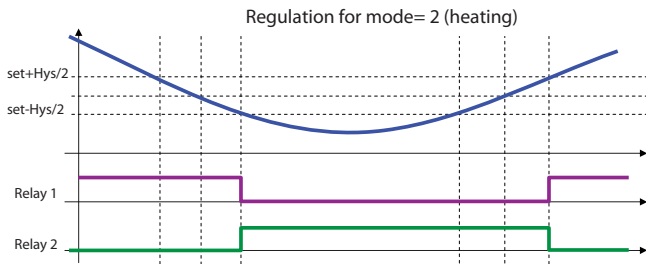

Fig. 10.g

Control in the event of probe faults

In the event of a probe fault control is disabled and both relays are deactivated.

Mode =3 (Manual)

In this mode the state of the relay is controlled by CS_01 and CS_02.

Mode =4 (Manual with button input)

In the same way as for mode 3, the relays are controlled by CoilStatus[1] and CoilStatus[2].

In addition, the state of relay 1 is also controlled by a button connected to digital input IN_1 and relay 2 by a button connected to digital input IN_2.

Operating the button reverses the logic of the related output.

Mode =5 (Manual with switch input)

In the same way as for mode 3, the relays are controlled by CoilStatus[1] and CoilStatus[2].

In addition, the state of relay 1 is also controlled by a button connected to digital input IN_1 and relay 2 by a button connected to digital input IN_2.

Operating the button reverses the logic of the related output.

10.5 RC Router-Pulse Counter

The RC Router-Pulse Counter has 2 digital inputs and 2 probe inputs, and the same functions and same parameters as the CI Pulse Counter battery version.

It is used in all applications that require monitoring of electricity, water and gas consumption when the digital inputs have a high switching frequency (the life of the battery version would be too short, as each opening and closing of the digital contact causes wireless communication to update the parameters).

The data are saved to static memory every 6 hours, in the same way as the battery version, and in the event of power failures the data is retained in the memory without loss.

For the features, operating modes and supervision, see this manual under the section on the CI Pulse Counter..

Special commands – Command password

The special commands can be used to activate certain functions on the devices via the wireless network.

The command is executed when parameter CS_00 is set to 1.

HR_00 (HEX)	HR_00 (DEC)	Action
0x01F5	501	Delete Pulse Counter IN_1
0x01F6	502	Delete Pulse Counter IN_2
0x01F7	503	Set Counter IN_1 with value for Password 2,3
0x01F8	504	Set Counter IN_2 with value for Password 2,3

Tab. 10.b

10.6 Technical specifications

		Product code						
		RO Router Code W501RC1M20	EPT Router-Sensor Code W501VB2M10	Router-Sensore EPT ITC Codice W501XB2M*	RB Router-Bridge Code W501RB2M20	Router-Actuator Code W501H02M20	Route-Pulse counter Code W501N02M20	
Power supply	For 12-24 Vac/dc $\pm 10\%$ 100mA 50/60 Hz versions use a class II safety transformer with minimum power rating 2 VA. 12 Vac transformer recommended	Router 230Vac, Italian plug f or 230 Vac mains	12-24 Vac/dc $\pm 10\%$ 100mA; 50/60 Hz	12...24 Vac/dc $\pm 10\%$ 100mA; 50&60Hz	12-24 Vac/dc $\pm 10\%$ 100mA; 50/60 Hz	24 Vac/dc $\pm 10\%$ 100mA; 50/60 Hz	12-24 Vac/dc $\pm 10\%$ 100mA; 50/60 Hz	
Maximum power input	1 VA	x	x	x	x	x	x	
Radio frequency specifications	Frequency: selectable from 2405 to 2480 MHz (by parameter or automatically, see Table of supervisor parameters) Wireless protocol: ZigBee™	x	x	x	x	x	x	
Power transmitted	→	+10dB	+10dB	+10dB	0dB	+10dB	+10dB	
Operating conditions	-40T50°C, <80% RH non-condensing	x	x	x	x	x	x	
Storage conditions	-20T70°C, <80% RH non-condensing							
Connections - screw terminals for 12.24 Vac/ dc power supply	Power supply terminal: plug-in cables max size 1.5 mm	-	x		x	x	x	
230 Vac version connections		cable L=1.5m Italian plug	-		-	-	-	
Type of cable for serial connection	Shielded cable max length 1000 m							
Range of temperature reading for NTC probes 1 and 2	-50T90°C, <80% RH non-condensing	-	-		x	-	-	
Precision of temperature measurement	$\pm 1\text{ }^\circ\text{C}$ -10T30°C; $\pm 2\text{ }^\circ\text{C}$ -30T40°C	-	x		-	x	-	
Temperature measurement inputs	Measurement from -50 to + 90 C. Resolution 0.1 C. Compatible with standard CAREL probes 10 KOhm @25C (B3435)	-	-		x	-	-	
NTC sensors	Built-in	-	-	2 NTC	-	-	-	
Digital inputs	For voltage-free contacts (isolated) - Closing current 0.01mA. Use self-cleaning contacts (Open connector transistor or Reed Switch).	-	-		x	-	-	
Digital outputs	1 A 24 Vac/dc	-	-	-	-	x	-	
Assembly	wall-mounted by screws	-	-		x	-	-	
Display/Configuration	Read and write parameters via RS485	-	-		x	-	-	
Protocol	Modbus	-	-		x	-	-	
Index of protection	IP55 (see note 1)							
Classification according to protection against electric shock	Can be integrated into class I or class II appliances							
Environmental pollution	Normal							
PTI of insulating materials	250 V							
Period of stress across the insulating parts	Long							
Category of resistance to heat and fire	category D (box and cover)							
Immunity against voltage surges	category 2							
Software class and structure	Class A							
Disposal	Observe local legislation for the disposal of electrical material							
Accessories	TRASP3E120 - Plug-in transformer 3VA 230-12Vac TRADR4W012 - Electrical panel transformer 3VA 230-12Vac							

Tab. 10.c

Key:
 x → Included
 - → Not featured

Note: The index of protection is maintained only if a cable with an outside cross-section of less than 8 mm is used.

10.7 List of Router system variables (alphabetical order)

AP_RX_RADIO_LEV	RSSI of the last message received from the Gateway. Indicates the wireless signal level between the router and Access Point or Router. For further information see Z-Config;
CONNECTED_UNIT	Number of units (end devices) connected to the repeater;
FW_VERSION	FW revision
MAC_ADDR_0	Unique 32 bit unit identifier (1=MSB, 0=LSB). Uniquely identifies each device
MAC_ADDR_1	Unique 32 bit unit identifier (1=MSB, 0=LSB). Uniquely identifies each device
MACHINE_CODE	Supervisor peripheral identifier;
NET_PANID	Defines the device address for operation inside the network.
ON_LINE_STATUS	Indicates the entry status (0xFF=slot empty; 0=Router timeout; 1=Router on);
QUALIY_CONN_SIGNAL	Parameter for internal use;
ROUTER_GOOD_SIGNAL	Number of nearby routers with a good wireless signal $\geq 30\text{dB}$;
ROUTER_NEARBY	Number of nearby Routers. Indicates the number of routers near the device;
RX_MESSAGE_CNT	Parameter for internal use to check the wireless network;

Tab. 10.d

10.8 List of Router parameters

The following parameters are valid for the RO Router as well as for the Router function on the following devices:

- EP1 Router-Sensor;
- RB Router-Bridge;
- RA Router-Actuator;
- RC Router-Pulse Counter

Variable Index	Name	Description	Def.	Min	Max	UoM	"Type R/W"
IR0	'ON_LINE_STATUS'	'Slot status (0xFF=empty; 0=time out; 1=on)'	-	0	1	-	R
IR1	'MACHINE_CODE'	'Unit type - machine code (es: 101=Router Bridge 12..24Vac/dc; 108=Router 230Vac)'	101/108	-	-	-	R
IR2	'FW_VERSION'	'Firmware version (Major/Minor)'	2051	-	-	-	R
IR3	'MAC_ADDR_0'	'Units unique identifier Mac-Address LSB'	-	0	65535	-	R
IR4	'MAC_ADDR_1'	'Units unique identifier Mac-Address MSB'	-	0	65535	-	R
IR5	'NETWORK_ID'	'Network address'	-	0	65535	-	R
IR6	'QUALITY_CONN_SIGNAL'	'Quality signal (internal use)'	-	0	255	-	R
IR7	'AP_RX_RADIO_LEV'	'Radio Lev. for AP Rx messages'	-	0	100	dBm+100	R
IR8	'ROUTER_NEARBY'	'Number of Routers nearby'	-	0	16	-	R
IR9	'ROUTER_GOOD_SIGNAL'	'Number of Router nearby with good connection'	-	0	16	-	R
IR10	'CONNECTED_UNIT'	'Number of Connected units (On-line units) End Devices to Router'	-	0	32	-	R
IR11	'RX_MESSAGE_CNT'	'Counter - AP Rx messages'	-	0	65535	-	R

Tab. 10.e

10.9 List of RA Router-Actuator parameters

Modbus registers	Name	Description	Def.	Min	Max	UoM	"Type R/W"
HR0	CMD_PASSW_1	'Command Password (1)'	0	0	65535	-	R/W
HR1	TRANSM_CYCLE	'TX data cycle time'	20	5	3600	sec	R/W
HR2	LO_TEMP_TRESHOLD	'Threshold low Temp.'	0	-500	500	0,1°C	R/W
HR3	HI_TEMP_TRESHOLD	'Threshold high Temp.'	300	-500	500	0,1°C	R/W
HR4	HYSTERESIS_SET	'Hysteresis'	20	10	100	0,1°C	R/W
HR5	SET_POINT	'Set point'	200	-500	500	0,1°C	R/W
HR6	MODE	'Operating mode (0=off; 1=cool; 2=hot; 3,4,5= manual)'	0	0	5	-	R/W
HR7	DEF_TIME	Time defrost	10	1	60	min	R/W
HR8	DEF_INTER	Defrost interval	8	1	24	h	R/W
IR0	MACHINE_CODE	'Unit type - machine code'	69	-	-	-	R
IR1	FW_VERSION	'Firmware version (Major/Minor)'	2051	-	-	-	R
IR2	TX_MESSAGE_CNT	'Total Number of TX radio messages'	0	0	65535	-	R
IR3	RX_MSG_LEVEL	'Radio signal Level'	-	0	100	dBm+100	R
IR4	TEMPERATURE	'Temperature Value'	-	-500	1000	0,1°C	R
IR5	MAC_ADDR_0	'Unit unique identifier Mac-Address LSB'	-	0	65535	-	R
IR6	MAC_ADDR_1	'Unit unique identifier Mac-Address MSB'	-	0	65535	-	R
IR7	ID_SER_ADDR	'Carel_ID, Serial_Address, DIP-SW value'	-	16	127	-	R
IR8	LAST_RX_DELAY	'Time from last AP Rx message'	-	0	65535	-	R
IR9	RX_MESSAGE_CNT	'Counter - AP Rx messages'	-	0	65535	-	R
IR10	TIME_STAMP	'Time stamp for Temp. readings (100*hour+minute)'	-	0	2359	hh*100+mm	R
IR11	AP_RX_RADIO_LEV	'Radio Lev. for AP Rx messages'	-	0	100	dBm+100	R
IR12	NETWORK_ID	'Network address'	-	0	65535	-	R
IR13	'MIRROR_IS'	'Mirror Input Status (internal use)'	-	0	65535	-	R
CS0	EN_CMD_PW	'Trig. PWD (internal use)'	0	0	1	-	R/W
CS1	SET_RELE1	'Setting of relay 1 (operating mode = 3 manual)'	0	0	1	-	R/W
CS2	SET_RELE2	'Setting of relay 2 (operating mode = 3 manual)'	0	0	1	-	R/W
CS3	IN_1_POL	'IN_1 Digital input polarity'	0	0	1	-	R/W
CS4	IN_2_POL	'IN_2 Digital input polarity'	0	0	1	-	R/W
CS5	EN_NTC	'Enable Probe NTC'	1	0	1	-	R/W
IS0	HI_TEMP_ALARM	'High Temperature Alarm'	-	0	1	-	R
IS1	LO_TEMP_ALARM	'Low Temperature Alarm'	-	0	1	-	R
IS2	RELE1_STATUS	'Status Relay 1'	-	0	1	-	R
IS3	RELE2_STATUS	'Status Relay 2'	-	0	1	-	R
IS4	IN_1_STATUS	'Digital Input State IN_1 (1=open CA, 0=closed CC)'	-	0	1	-	R
IS5	IN_2_STATUS	'Digital Input State IN_2 (1=open CA, 0=closed CC)'	-	0	1	-	R
IS6	PROBE_ERROR	'Probe Failure Alarm'	-	0	1	-	R

Tab. 10.f

For further information, see page 34

Key:

HR = Holding register; IR = Input register; CS = Coil Status; IS = Input Status

10.10 Installation notes

1. Remove the cover;
2. Fasten the case to the wall with minimum two screws, remembering that this is a radio device and therefore the necessary details must be observed.
3. Connect:
 - Power supply;
 - NTC temperature sensors (10K@25°C Beta(25/85) = 3435K) (models where featured);
 - Digital inputs (models where featured);
 - Analogue input (models where featured);
4. Select the network address by dipswitch (for versions that feature the integrated functions).
5. Open the Access Point wireless network (binding is performed automatically).
6. Check the quality of the wireless signal.
7. Close the device again.
8. Make sure that the transmitter is in an optimum position with reference to the receiver, once installation is complete, checking the transmitted signal level in the corresponding supervisor variable.

10.11 Electrical connections and physical dimensions

• RO Router 230 Vac ver.

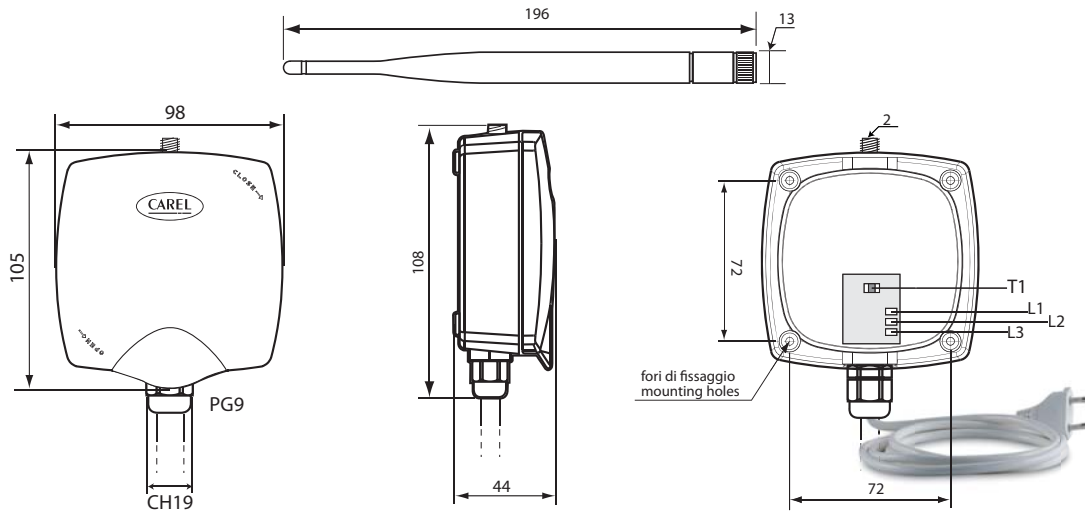
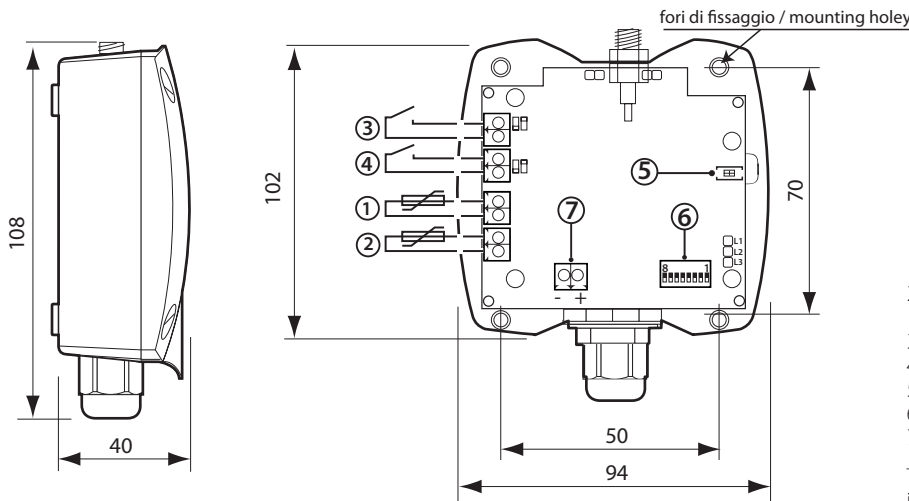

Fig. 10.h

If the device is used with a different power outlet, cut the cable and connect a plug that meets requirements.

• EP1 Router-Sensor / Router counter RC



1. Probe input NTC_110K@25°C Beta(25/85) = 3435K (e.g. NTC*HP* or NTC*WP*);
2. Probe input NTC_2 10K@25°C Beta(25/85) = 3435K (e.g. NTC*HP* or NTC*WP*);
3. Defrost digital input (IN_1) can be configured N.C. or N.O.;
4. Door digital input (IN_2) can be configured N.C. or N.O.;
5. Binding/unbinding button;
6. Dipswitches for setting serial address;
7. 12-24 Vac/dc power supply

The maximum cable length for NTC probes and digital inputs is 10 m.

Fig. 10.i

• RB Router-Bridge

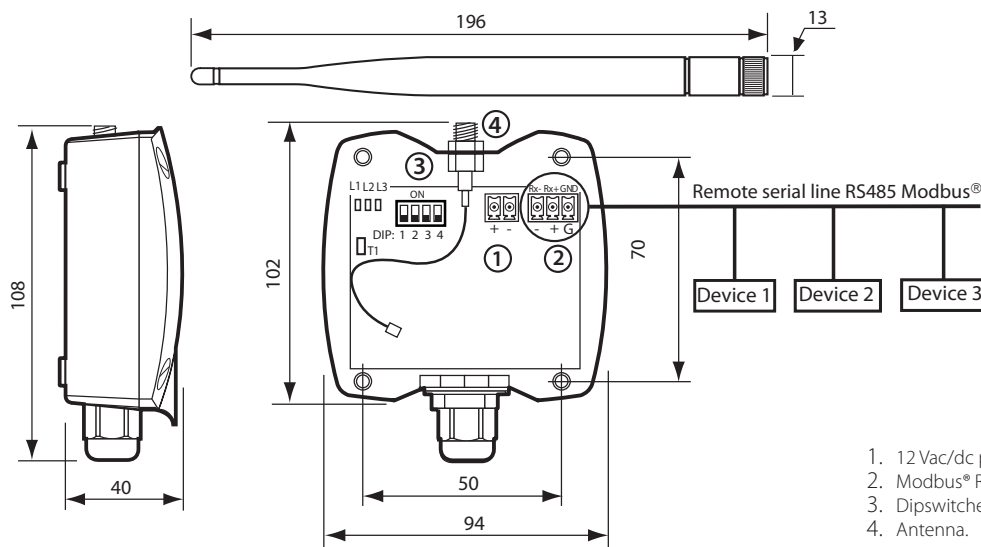

1. 12 Vac/dc power supply;
2. Modbus® RS485 serial connection;
3. Dipswitches for serial address;
4. Antenna.

Fig. 10.j

• RA Router-Actuator

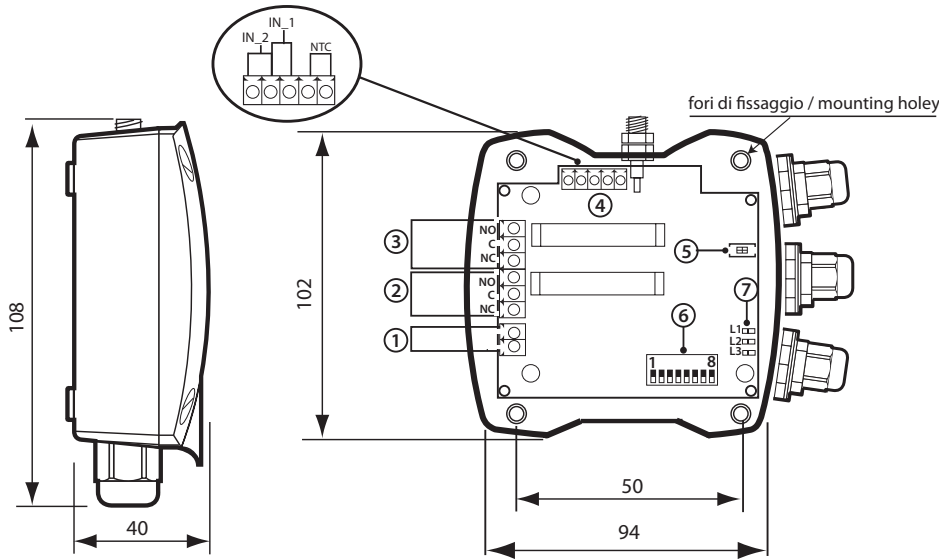

- 1. 12... 24 Vac/dc power supply;
- 2-3 SPDT relay output;
- 4. I/O (digital & analogue inputs);
- 5. Binding/unbinding button;
- 6. Configuration dispswitches;
- 7. LEDs.

Fig. 10.k

• RC Router-Pulse Counter

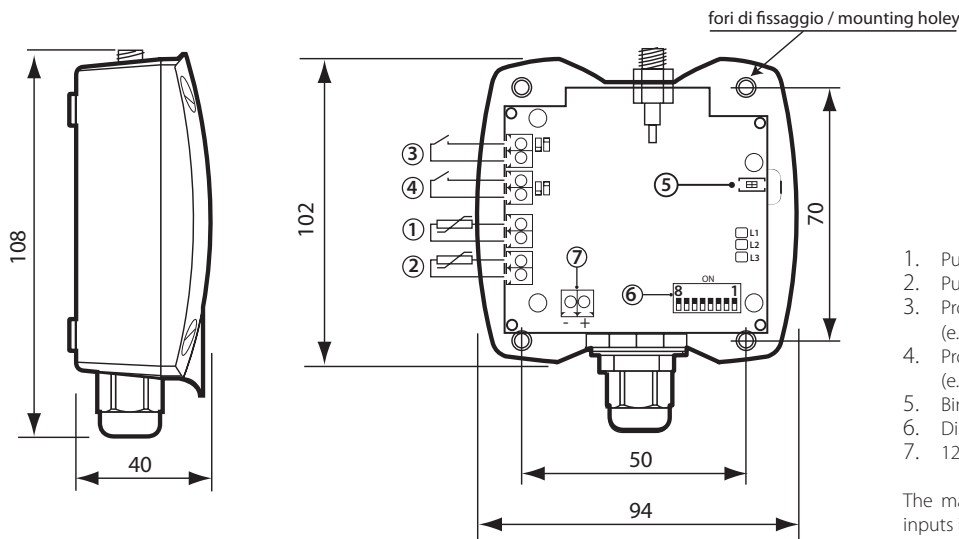

- 1. Pulse counter digital input 1 (IN_1);
- 2. Pulse counter digital input 2 (IN_2);
- 3. Probe input NTC_1 10K@25°C Beta(25/85) = 3435K (e.g. NTC*HP* or NTC*WP*);
- 4. Probe input NTC_2 10K@25°C Beta(25/85) = 3435K (e.g. NTC*HP* or NTC*WP*);
- 5. Binding/unbinding button;
- 6. Dipswitches for setting serial address;
- 7. 12-24 Vac/dc power supply

The maximum cable length for NTC probes and digital inputs is 10 m.

Fig. 10.l

Note: all the measurements are in mm.

10.12 General warnings

Fasten the device to the wall with the cable gland facing downwards; Tighten the antenna in its housing (4), and position it vertically to the floor; Connect the power supply to the terminal (1), ensuring the polarity indicated for DC power supply (12 to 24 Vac/dc version).

A 12 Vac transformer is recommended for the device 12-24 Vac versions. For correct operation the system must be powered at all times, in the event of power failures there may be a unit reset time (OFFLINE) based on the data transmission cycle.

IMPORTANT:

If the same power supply is shared by more than one unit, connect the same wire from the transformer to the power supply "-" terminal (1).

11. PLUGS E SWITCH

11.1 General features



Fig. 11.a

The rTM wireless Plug and Switch devices are modules with the same features and are proposed with different electrical connections for adaptation to specific requirements. They comprise an energy meter and a control relay that can handle up to 2.5 kW single-phase electrical loads. These devices are installed between a normal 230 Vac power socket and the load being controlled.

After having bound them to a Carel wireless network, the relay can be controlled via a remote wireless connection in on/off mode, and instant power consumption of the connected appliance can be measured.

A local button is available to override relay operation (on/off) and monitor status via serial line.

In the wireless network, these devices act as Routers, transferring wireless traffic between other compatible rTM SE system devices. They send the data wirelessly using the ZigBee™ communication protocol, communicating with the Access Point connected via a Modbus RTU RS485 serial line to a CAREL system.

The devices are powered via the same 230 Vac socket they are plugged into.

Typical applications:

The device can be used with the following products:

- Carel pLoads (smart management of electrical loads), to control the loads and manage the maximum deliverable power available and read power consumption for each load, so as to implement power savings.
- PVPRO and PWPRO supervisors for analysis of power consumption;
- Carel controllers for managing electrical loads.

Available in the versions with plugs for:

- Italy;
- Great Britain;
- France;
- Germany (Schuko);
- Universal;

Warning: these devices must only be installed by qualified personnel.

Binding the device

- When the Plug/Switch is connected for the first time, the yellow LED is on steady while the device searches for the wireless network Access Point to bind to. If communication cannot be established, after 20s the LED flashes to indicate it the device is searching again.
- To assign the Plug/Switch to a network, press button T1 on the corresponding Access Point (to open the wireless network). When the device has been correctly bound to the network, the yellow LED on the Plug/Switch starts flashing.
- Close the wireless network and assign a serial address between 16 and 126 using the button (see the button functions), or alternatively using the rTM handheld, making sure not to set duplicate addresses.
- Connect the electrical load and make sure that this is continuously powered at mains voltage, between 85 and 250 Vac (max 2500 W). To assign the device to another Access Point, unbind from the network and reset the default address (127).
- The device can only be assigned to one Access Point at a time;

11.2 Operation

Behaviour of the TWO-COLOUR LED during normal operation

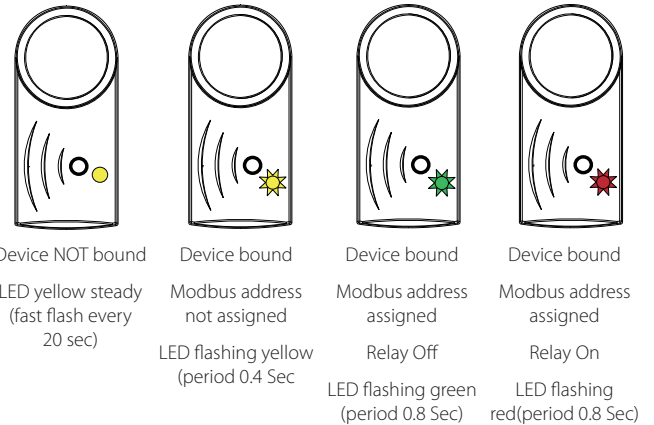

Fig. 11.b

Pressing the button with the device not bound

If the device is not bound to a network, pressing the button has no effect.

Pressing the button with device already bound

If the device is bound to a network, pressing the button instantly causes the LED to flash quickly, green-red-yellow, as feedback.

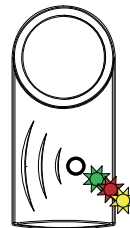

Feedback when pressing the button: Green-red flash-yellow (interval 50mS, total 150mS)

Pressing the button once – switch the relay

Pressing the button once (and releasing it within one second) switches the device relay (activating the relay if off, deactivating the relay if on). Switching is effected one second after the button is pressed, then the LED stays on for three seconds (green or red, depending on the new relay status), after which the behaviour of the LED returns to normal.

Pressing and holding the button – unbind the device

Pressing and holding the button for between 6 and 18 seconds unbinds the device (removing it from the network it was previously bound to).

Two types of unbinding are possible:

1. Reset and keep the serial address: The device is removed from the network but maintains the previously assigned Modbus address.
2. Reset and assign the default serial address (127): The device is removed from the network and its Modbus address is set to the default, 127.

To reset and keep the serial address, press and hold the button for between 6 and 12 seconds.

To reset and assign the default serial address (127), press and hold the button for between 12 and 18 seconds.

Pressing and holding the button for less than 6 seconds has no effect.

Pressing and holding the button for more than 18 seconds has no effect.

The LED turns green during the interval in which the device is reset while keeping the serial address, and red during the interval in which it is reset and address 127 is assigned.

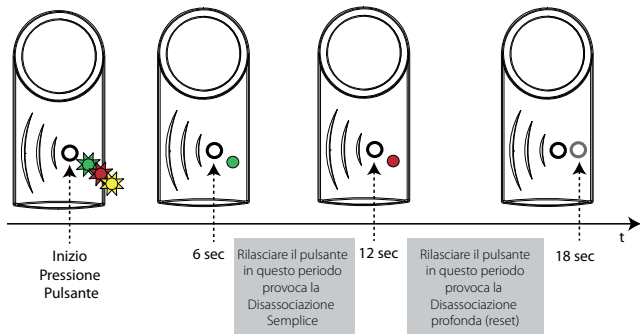

Fig. 11.c

Pressing the button twice – display the Modbus address

Pressing the button twice (twice separately, for no longer than one second and no more than one second apart) accesses Modbus address display mode. This mode can only be activated if the device Modbus address has been assigned. This mode is indicated by a sequence of green-red- yellow flashes of the LED for 0.5 seconds.

After entering this mode, the LED performs a sequence of red flashes, followed by a sequence of green flashes. The number of red flashes indicates the tens of the Modbus address, while the number of green flashes indicates the units of the Modbus address. In both cases, the flashing of the LED comprises the LED coming on for 0.1 seconds followed by the LED off for 0.5 seconds. Between the sequences of flashes when entering the mode, the count of the tens and the count of the units, there is a 2 second pause with the LED off.

Example (1):

Modbus address = 57

Sequence:

- Normal operation (Modbus address assigned)
- Button pressed the first time – green-red-yellow feedback
- Button pressed the second time – green-red-yellow feedback
- LED off for 1 second
- Enter display mode (green-red-yellow flash for 0.5 seconds)
- LED off for 2 seconds
- 5 red flashes (duration $5 \cdot 0.6 = 3.0$ seconds)
- LED off for 2 seconds
- 7 green flashes (duration $7 \cdot 0.6 = 4.2$ seconds)
- LED off for 2 seconds
- Return to normal operation

Example (2):

Modbus address = 119

Sequence:

- Normal operation (Modbus address assigned)
- Button pressed the first time – green-red-yellow feedback
- Button pressed the second time – green-red-yellow feedback
- LED off for 1 second
- Enter display mode (green-red-yellow flash for 0.5 seconds)
- LED off for 2 seconds
- 11 red flashes (duration $11 \cdot 0.6 = 6.6$ seconds)
- LED off for 2 seconds
- 9 green flashes (duration $9 \cdot 0.6 = 5.4$ seconds)
- LED off for 2 seconds
- Return to normal operation

Pressing the button four times – set the Modbus address

Pressing the button four times (four times separately for no longer than one second and no more than one second apart) enters Modbus address programming mode. This mode can only be activated if the device Modbus address has NOT already been assigned. This mode is indicated by a sequence of green-red- yellow flashes of the LED for 1.5 seconds.

After entering this mode, the LED goes off and the device waits for the button to be pressed; data entry is divided into two stages, entering the tens and entering the units.

Stage (1) – Setting the tens of the Modbus address

The number of times the button is pressed during this stage represents the tens of the new Modbus address. During this stage, pressing button causes the LED to flash red; the button must be pressed a number of times between 1 and 12. The first stage ends 3 seconds after the button is pressed the last time. At the end of the first stage, the LED flashes green-red-yellow to indicate the start of the next stage.

Stage (2) – Setting the units of the Modbus address

The number of times the button is pressed during this stage represents the units of the new Modbus address. During this stage, pressing button causes the LED to flash green; the button must be pressed a number of times between 0 and 9. The second stage ends 3 seconds after the button is pressed the last time.

At the end of the second stage, the number entered is checked; if it is between the allowed limits (from 16 to 126 inclusive), the LED flashes green-red-yellow to indicate that the setting has been completed, the device saves the new Modbus address and finally is reset (power off/on). If the value entered is not compliant, the device exits programming mode and returns to the previous status, without having any further effect.

Example (3):

Desired Modbus address = 98

For address assignment using the handheld, see the section “rTM handheld”.

Change the Modbus address

To change the device Modbus address (if set incorrectly), first unbind and reset the device (pressing the button for between 12 and 18 seconds), then bind the device to the network again (opening the network on the Access Point), and finally repeat the address assignment procedure described above.

11.3 Functions

Button	LED	Relay status	Action / Remarks
	Yellow steady (fast flash every 20 s)	OFF	Device not bound
	Yellow flashing		Device bound, without Modbus address.
press once	Yellow flashing Green for 3 s Yellow flashing	OFF	Device bound, without Modbus address . Change relay status (ON).
press once	Yellow flashing Red for 3 s Yellow flashing	ON	Device bound, without Modbus address. Change relay status (OFF).
press 4 times (no longer than 1 second)	Assign the serial address (valid only if the Modbus address has not already been assigned): - after the first green-red-yellow flash (fast); - press the button a number of times corresponding to the tens of the desired Modbus address. Each time the button is pressed, the red LED will come on; - wait until the second green-red-yellow flash (fast) ; - press the button a number of times corresponding to the units of the address to be assigned. Each time the button is pressed, the green LED will come on; - wait until the third green-red-yellow flash (fast), signalling the end of the procedure. Check the address that has been assigned;		
press 2 times (no longer than 1 second)	Display the serial address. Count: - no. of flashes of the red LED (multiply by 10); - no. of flashes of the green LED (multiply by 1); To determine the serial address, sum the above results.		
	Green flashing	Relay ON	Device bound, with Modbus address.
	Red flashing	Relay OFF	Device bound, with Modbus address.
press and hold between 6 & 12 seconds			Unbind from the wireless network, retaining the previously assigned serial address
press and hold between 12 & 18 seconds			Unbind from the wireless network, resetting the serial address to the default 127 (reset)

To change the Modbus address, unbind from the network, resetting the default address 127 and then assign the new address;

Tab. 11.a

11.4 Technical specifications

Power supply	85-250 Vac
Radio frequency specifications:	selectable from 2405 to 2480 MHz Stack EmberZNet3.5.x
Wireless protocol:	ZigBee (IEEE 802.15.4 compliant)
Rated transmission power:	2 mW (3dBm)
Range	30 m
Measurements:	active power (W), energy consumed (Wh) energy consumption over time (s)
Operating conditions:	-10°C/55 °C - humidity range: <80% RH non-cond.
Storage conditions:	-20/70 °C - humidity range: <80% RH non-cond.
Digital output:	250 Vac 10 A resistive incandescent lamps 10 A fluorescent lamps / transformers 4 A
Expected life:	100,000 cycles with resistive load
Plugs:	Italian, French, British, German (Schuko)
Ingress protection against atmospheric agents:	IP30
Classification according to protection against electric shock:	Can be integrated into class I or class II appliances
Environmental pollution:	Normal
PTI of the insulating material:	250 V
Period of stress across the insulating parts:	Long
Category of resist. to heat and fire:	Category D
Overvoltage category	Category II
Software class and structure:	Class A
Compatible with reference directives 2006/95/EEC, 89/336/EEC, 99/5/EEC:	ETSI EN 300 328: Wideband transmission systems ETSI EN 301 489: Electromagnetic Compatibility (EMC) standard for radio equipment and services EN 55014-1:2006 + A 1:2009: Electromagnetic compatibility - Immunity EN 61000-3-2:2006: Electromagnetic compatibility - Emissions EN 61000-3-3:2008: Electromagnetic compatibility - Emissions EN 55014-2: Electromagnetic compatibility - Immunity
Part numbers	WS01C010I0: rTM Plug - Italian WS01C010G0: rTM Plug - British WS01C010F0: rTM Plug - French WS01C010E0: rTM Plug - German (European Schuko) WS01C010X0: rTM Switch - Universal

Tab. 11.b

11.5 List of Plug/Switch parameters

The following parameters apply to Plug and Switch devices with Router function:

Var. index	Name	Description	Def.	Min	Max	UoM	Type
HR0	CMD_PASSW_1	Command passw. (1)	-	0	1	-	R/W
HR1	TRANSM_CYCLE	Transmission time	20	1	3600	sec	R/W
IR1	FW_VERSION	Firmware version	2058	-	-	-	R
IR3	RX_MSG_LEVEL	Level of the radio signal	-	0	100	dBm+100	R
IR5	POWER	Active power	-	0	65535	W	R
IR6	ENERGY	Energy consumed	-	0	4294967296	Wh	R
IR10	MAC_LSB	MAC address (LSB)	-	0	65535	-	R
IR11	MAC_MSB	MAC address (MSB)	-	0	65535	-	R
IR12	ID_SER_ADDR	ID Serial Address	127	1	126	-	R
IR13	MACHINE_CODE	Type of device	306	-	-	-	R
IR14	LAST_RX_DELAY	Seconds passed since receiving last messages	-	0	65535	-	R
IR15	RX_MESSAGE_CNT	Counter of messages received from Access Point	-	0	65535	-	R
IR16	TIME_STAMP	Clock Counter as hh.mm for RX-data TimeStamp	-	0	2359	hh*100+mm	R
IR17	AP_RX_RADIO_LEV	Signal Level of the last message received from Access Point	-	0	100	dBm+100	R
IR18	NETWORK_ID	Device network address	-	0	65535	-	R
CS0	EN_CMD_PW	Command password activation	0	0	1	-	R/W
CS1	SET_RELE_ON	Electric load is set to ON	0	0	1	-	R/W
CS2	SET_RELE_OFF	Electric load is set to OFF	0	0	1	-	R/W
CS4	RES_DATA	Reset measurement data	0	0	1	-	R/W
IS0	RELE_STATUS	Output State	0	0	1	-	R

Tab. 11.c

11.6 Installation notes

Connect the Plug and Switch in the desired position, remembering that it is a radio device and as a consequence the following simple rules must be observed:

- Avoid enclosing the device between two metal walls;
- The efficiency of radio transmission is reduced when there are obstacles, metal shelving or other objects that may block the reception of the wireless signals;
- If the product is wall-mounted, fasten it to a masonry wall rather than a metal wall, to improve the range of the signal;
- Remember that the best position is one where it is "visible" to the other devices (Access Points or Repeaters). It should be positioned in such a way as to minimise any obstacles;
- Like all radio equipment, avoid installing the device near other electronic appliances, so as to avoid interference.
- Do not install the instruments in environments with the following characteristics:
 - strong vibrations or knocks;
 - exposure to water sprays;
 - exposure to direct sunlight or the elements in general.

If the appliance is used in a way that is not described by the manufacturer, the specified level of protection may be affected.

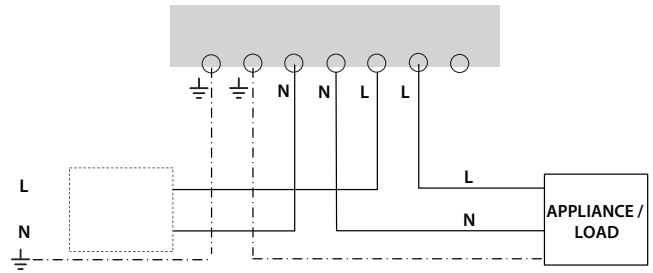

Fig. 11.f

Connection:

Connection	230 Vac 50 Hz
Max load	
Resistive	10A
Incandescent lamps	10A
Fluorescent lamps / transformers	4A

11.7 Plug connection example

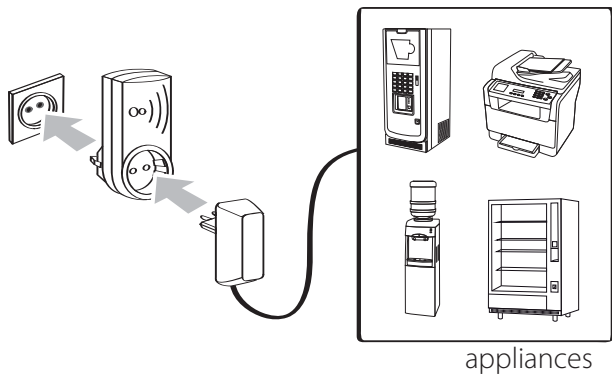

Fig. 11.d

11.9 Dimensions

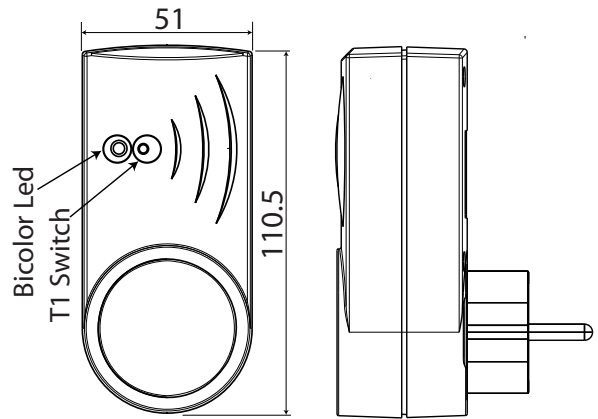

Fig. 11.g

11.8 rTM Switch electrical connections

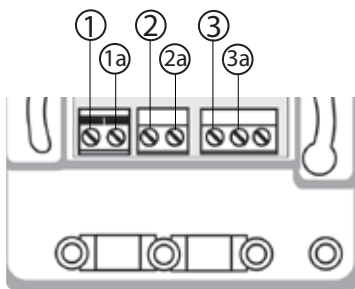

Fig. 11.e

Connection:
 ① GROUND
 ② NEUTRAL
 ③ LINE (L)

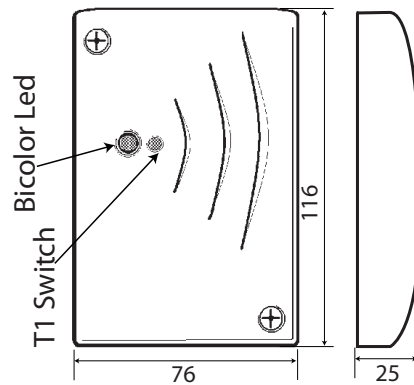

Fig. 11.h

12. GENERAL NOTES

12.1 Notes for correct installation

- To ensure correct operation of the ZigBee wireless system, the best possible connection must be guaranteed between the Access Point and the Router.
- The Router should preferably be installed at a height of around 2 to 3 m from the floor, not in contact with large metallic objects (air ducting etc.), so as to avoid the Router-Access Point connection being affected by obstacles such as cabinets, showcases, moving people, and where possible in direct line of sight with the other devices.
- Make sure that the path between the Router and the Access Point does not include metallic fire doors or large metallic obstacles (elevator compartment etc.) which may disturb the connection.
- When positioning the devices, check that the sensors have at least two wireless routes to the Access Point; that is, they can be seen by at least two Routers or one Router and the Access Point, and that the wireless signal levels, both in and out, are good. Remember that wireless devices are significantly affected by changing environmental conditions, unlike wired connections, and therefore each sensor should be able to reach the Access Point via at least two devices connected at the same wireless network, which may be an Access Point and Router, or two Routers. It's also recommended to set a delay on the supervisor (around 1 hour) for notifying alarm signals, so as to avoid false sensor offline warnings;
- Fasten the Access Point/Router in position, considering that as the device being installed is a radio device, the following simple rules must be observed:
 - The efficiency of radio transmission is reduced when there are obstacles, metal shelving or other objects that may block the reception of the wireless signals;
 - If the product is wall-mounted, fasten it to a masonry wall rather than a metal wall, to improve the range of the signal;
 - Like all radio equipment, avoid installing the Access Point near other electronic appliances, so as to avoid interference;
 - Connect the RS485 network to the terminal respecting the polarity.
- For correct operation the system must be powered at all times, in the event of power failures there may be a unit reset time (OFFLINE) based on the data transmission cycle;
- Do not install the instruments in environments with the following characteristics:
 - Strong vibrations or knocks;
 - Exposure to water sprays;
 - Exposure to direct sunlight or the elements in general;

If the devices are used in a way that is not described by the manufacturer, the specified level of protection may be affected.

12.1 Power supply connection

The 12-24 Vac/dc Access Point and Router can be powered using the CAREL 230/12 Vac 3 VA plug-in transformer code TRASP3E120, or electrical panel transformer code TRADR4W012, or any other 12 Vac 2 VA transformer.

For 12/24 Vac/dc versions, the maximum wire size for the terminals is 1.5 mm².

12.2 Wiring

To wire the serial connection to the Access Point or Router-Bridge local RS485 network, use 3-wire shielded cable. To ensure IP55 protection on the case, use a 5-wire cable, and relay the serial and power supply connections through an external junction box with terminal block.

The maximum wire size for the terminals is 1.5 mm². The maximum outside diameter of the cable must not exceed 8 mm, to allow it to pass through the cable gland.

Features of the serial connection cable

For connection to the Access Point, the cable used must have the following characteristics:

Twisted pair;

Shielded, preferably with earth wire;

Size AWG20 (diam. 0.7-0.8 mm; area 0.39-0.5 mm²);

Make sure that the cable shield is connected to EARTH on the supervisor connection side, and that the polarity of the connection is observed on all the units connected. The shield is normally connected to the reference on all the units.

Also pay careful attention when connecting the local network to the Router-Bridge, when using controllers connected in a local Modbus® RS485 network.

13. RTM SE HANDHELD

13.1 General Features

The rTM SE ZigBee™ handheld is a very useful device for the installation, control and maintenance of networks of rTM SE system wireless devices. It is not needed however for normal operation of the wireless network devices (sensors, Access Points, Routers).

For a limited operating period inside the network, the handheld represents a Router-like node on which the normal wireless traffic relaying functions are disabled. Its function is essentially to identify the wireless signal level in the area where the Sensor or Router-Bridge is being installed, so as ensure these are reached by the wireless signal, checking the signal level and how many receiving devices can be connected. In other words it identifies whether the position chosen for the installation of a new Sensor or Router is suitably covered by the wireless signal in question.

The rTM SE handheld also provides the following functions:

- Open and close the wireless network on the Access Point in order to bind other sensors, without having to press the local button on the Access Point or access it via the supervisor;
 - Reset Routers and Access Points associated with the wireless network;
 - Set the address of BP Sensors after binding these to an Access Point;
- Security of these operations is guaranteed by the network password that can be set on the rTM SE handheld.

It is consequently a tool that significantly simplifies the installation of the rTM SE system.

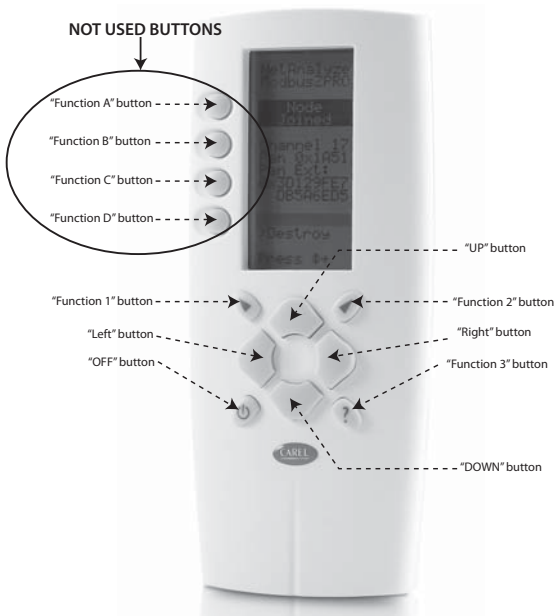

Fig. 13.a

13.2 Operating modes

The rTM SE handheld features two main operating modes:

- **Not connected**
the rTM SE handheld is not connected to any wireless network; in this case, it may try to connect to a network or alternatively can scan the ZigBee wireless channels.
Functions available in this mode:
 - Scan energy ("Ener.Scan" menu)
 - Scan networks ("Netw.Scan" menu)
 - Scan connection ("Join Scan" menu)
- **Connected to a network**
the rTM SE handheld is connected to a compatible network (Modbus / Carel); Only in this case can it activate the test function (Ping Test). Functions available in this mode:
 - Ping test
 - Network functions ("Commands" menu)
 - Unbinding ("Leave Net" menu)

13.3 Main menu

The structure of the main menu on the rTM SE handheld depends on the operating mode that is currently active and reflects the list of the functions described above.

- Main menu - not connected

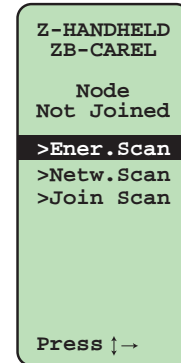

Fig. 13.b

- Main menu - connected to a network

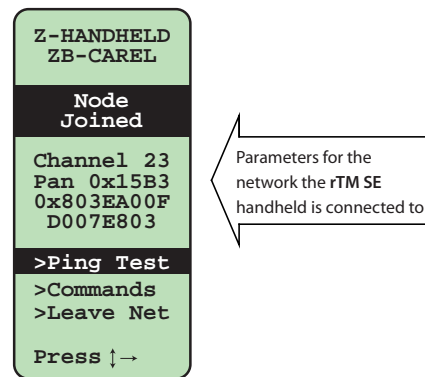

Fig. 13.c

In both cases, press the "Up" and "Down" buttons to scroll the menu; press the "Right" button to activate the selected function.

Adjusting contrast of the LCD

When the main menu is active (in either mode), pressing the "function 1" button reduces the contrast of the LCD; vice-versa pressing the "function 2" button increases contrast.

13.4 Scan Energy

The scan energy process measures the maximum RSSI value (Received Signal Strength Indication) on each of the 16 wireless channels. This value provides an indication of the degree of disturbance on each channel. The entire process lasts around one minute.

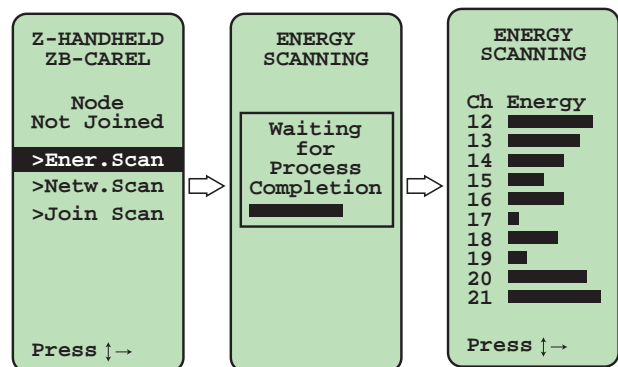

Fig. 13.d

Press the "up" and "down" buttons to scroll the values of all the channels, displayed in order. Press the "Left" button to return to the main menu.

13.5 Scan Networks

The scan networks process analyses all 16 wireless channels to search for ZigBee networks. The process lasts around 20 seconds. At the end of the process, the list of networks detected is displayed.

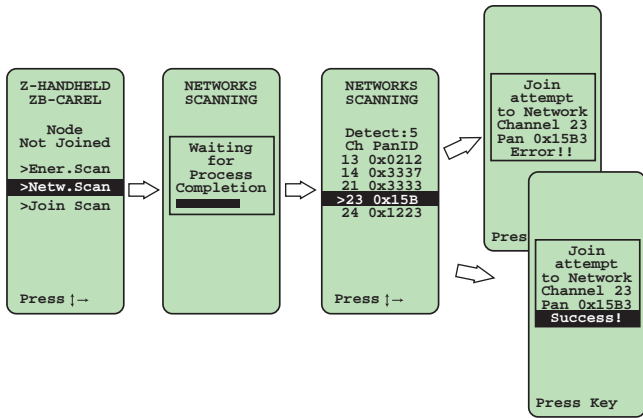

Fig. 13.e

Press the “up” and “down” buttons to select the desired network. Press the “Right” button to attempt to connect to the selected network. Press the “Left” button to return to the main menu.

13.6 Scan Connection

The scan connection process analyses all 16 wireless channels to search for a compatible open network. If a network with the required features is detected, the binding procedure is activated. The whole process lasts a maximum of around 25 seconds.

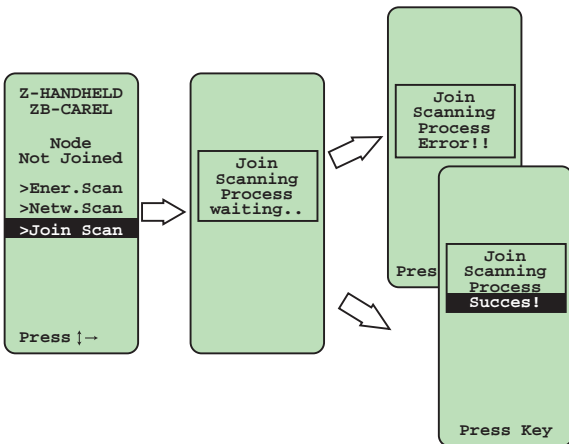

Fig. 13.f

13.7 Unbinding

The unbinding process disconnects the rTM SE handheld from the network it was previously bound to.

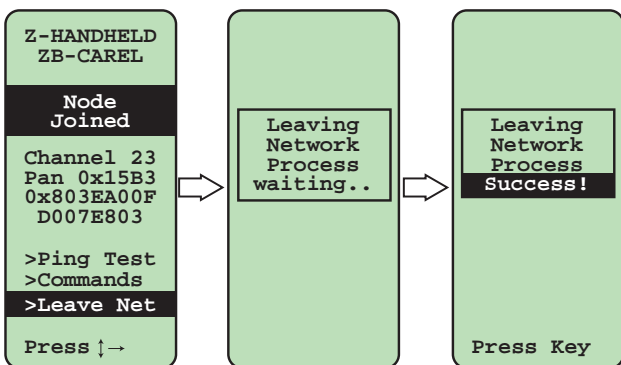

Fig. 13.g

13.8 Ping test

The Ping Test is the main function of the rTM SE handheld. It's used to identify the Routers that are operating within the operating range in the bound network. For each Router the two least significant digits of the unique device address (MAC ADDRESS) are shown, along with the signal level (RSSI).

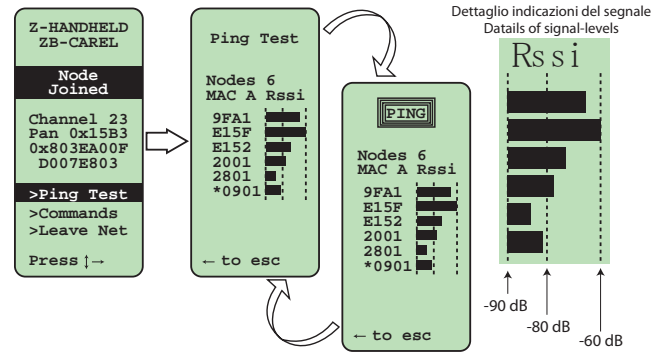

Fig. 13.h

Warning. Due to the reduced space available on the rTM SE handheld display, only the last 4 digits (LSB) of the MAC ADDRESS are displayed.

During this operation, the rTM SE handheld sends a wireless message to all the Router nodes in its operating range at regular 3 second intervals (unit range broadcast).

This event is highlighted by the “PING” message at the top of the display. The Router devices that receive the message respond with a message sent to the rTM SE handheld containing their address. The messages received by the rTM SE handheld are used to constantly update the values displayed.

The Ping Test lasts four minutes, after which the main menu is automatically displayed. Alternatively, the Ping Test can be ended by pressing the “Left” button. Pressing any other button repeats transmission of the wireless message.

The three vertical lines used to represent the RSSI indicate, from left to right respectively, a value of -90dB, -80dB, -60dB (for the supervisor these would be 10 dB, 20 dB, 40 dB)

The intermediate line indicating -80dB represents the threshold value below which the signal is not considered sufficient and above which it's considered good.

Note: The asterisk on the left next to the MAC ADDRESS indicates the coordinator node.

Either the device MAC ADDRESS or Modbus address can be displayed. To change the display mode, see the “View Mode” menu under “Commands”.

13.9 Network commands

The “Commands” menu is used to execute commands and make settings inside the network that the rTM SE handheld is connected to.

The following commands are available:

1. Address display setting (MAC ADDRESS / Modbus® address);
2. Open/close the network (for binding new devices);
3. Unbind a Router;
4. Set the Access Point password;
5. Set the Access Point password
6. Sensors menu

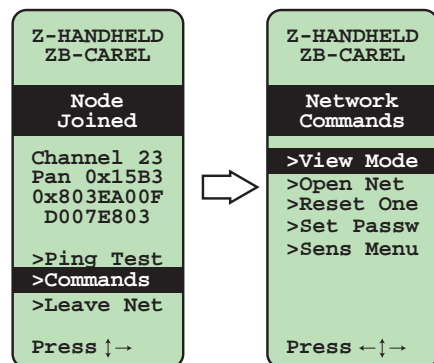

Fig. 13.i

13.10 "View Mode" menu

This menu is used to modify the display of Router addresses. By default the MAC ADDRESS is displayed; alternatively, the device Modbus address can be displayed.

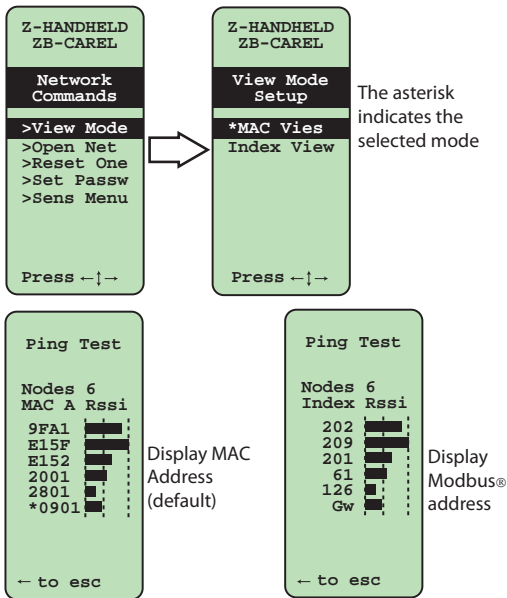

Fig. 13.j

Warning: When displaying the address of the EP1 Router-Sensor, only the sensor address (set on the dipswitches) is displayed, while the Router address is not displayed.

13.11 "Open Network" menu

This menu is used to cyclically send an open network message to all Router devices (including the Access Point). When the network is open new devices can be connected. The network remains open until closed manually ("Left" button) or automatically after 15 minutes. The menu can only be accessed after entering the correct Access Point password (if not equal to zero).

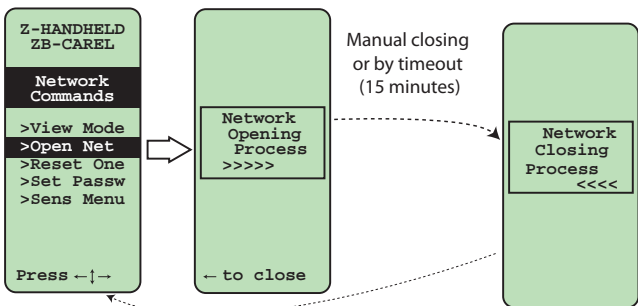

Fig. 13.k

13.12 "Reset One" menu

This menu is used to unbind an individual Router device (including the Access Point/Coordinator).

Once having accessed the menu, the handheld wireless signal level meter displays the list of the Router devices available in the vicinity. Select the required Router, a prompt is shown to confirm the unbinding command.

The menu can only be accessed after entering the correct Access Point password (if not equal to zero).

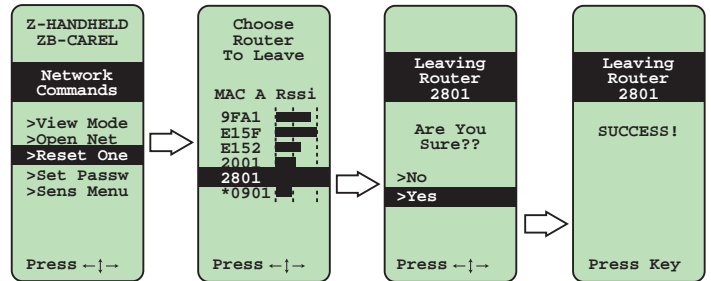

Fig. 13.l

13.13 Password entry menu

The functions for opening the network and unbinding the Routers require a numerical code in order to be accessed.

This numerical code must be the same as the Access Point password. The password is stored on the Access Point (HoldingRegister[13] on the Access Point, see the related documents). Before prompting to enter the code, the handheld device communicates with the Access Point to identify the password. For this reason, the Access Point must be on and have a compatible firmware version (firmware version 8.1 and higher).

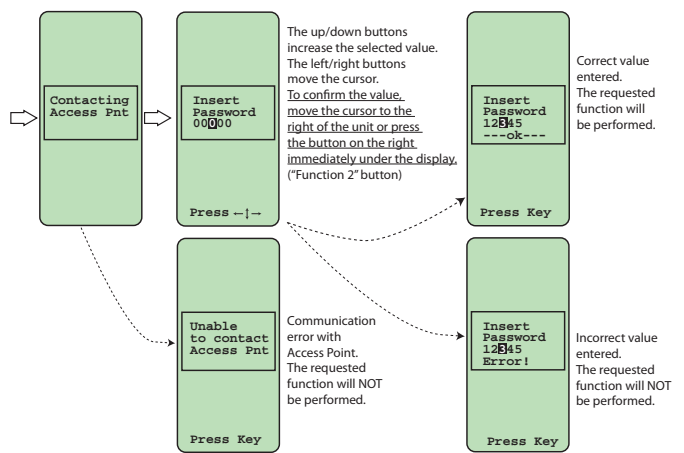

Fig. 13.m

If the password is zero (default value), the password entry prompt is not shown and the required function is performed immediately. If the password is equal to 65535 (0xFFFF), the password prompt is not shown and the required function is locked. In this case, the display shows the message "Function Disable". The password is only required when first accessing the open network menu or unbind router menu. The menus can then be accessed subsequently without entering the password; this continues until the commands menu is closed.

13.14 "Set Passw" Menu – Set Access Point password

This menu is used to set the Access Point password. The current value needs to be entered in order to modify the password.
 The Access Point password can be a number between 0 and 65534.
 The value 65535 (0xFFFF) cannot be set from the handheld, as this completely blocks access to the special functions. This value can only be set on the Access Point via direct serial communication.

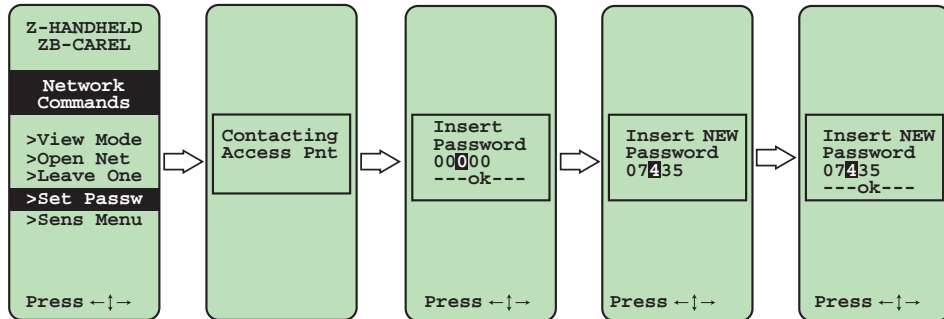

Fig. 13.n

13.15 Sensors menu

The sensors menu is used to execute commands on the sensors in the network. The following commands are possible:

- List of all the sensors in the network
- Set the address of special sensors (sensors without dipperswitches for setting the address).
- Unbind a sensor.

The menu can only be accessed after entering the correct Access Point password.

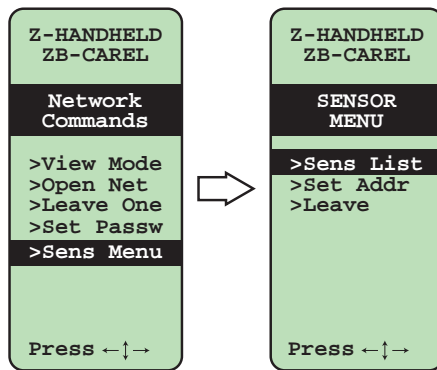

Fig. 13.o

13.16 List of Sensors

This menu displays the list of all the sensors installed in the network

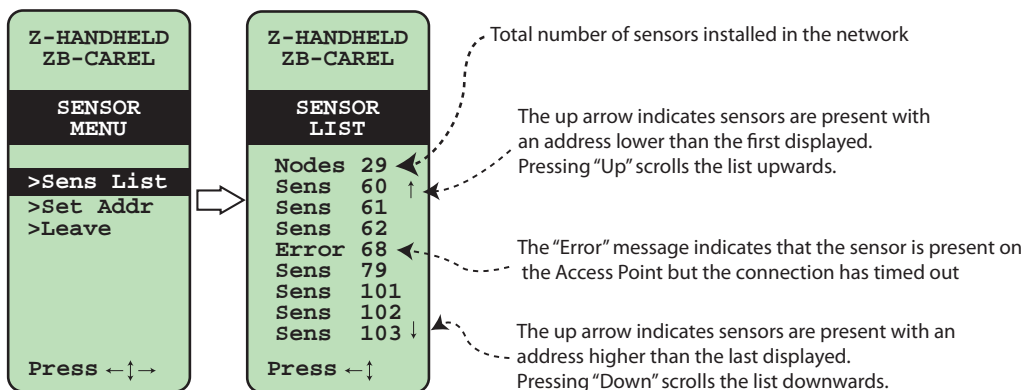

Fig. 13.p

13.17 Set Sensor address

The menu for setting the sensor address is used to assign the Modbus address to special sensors (sensors without dipperswitches).

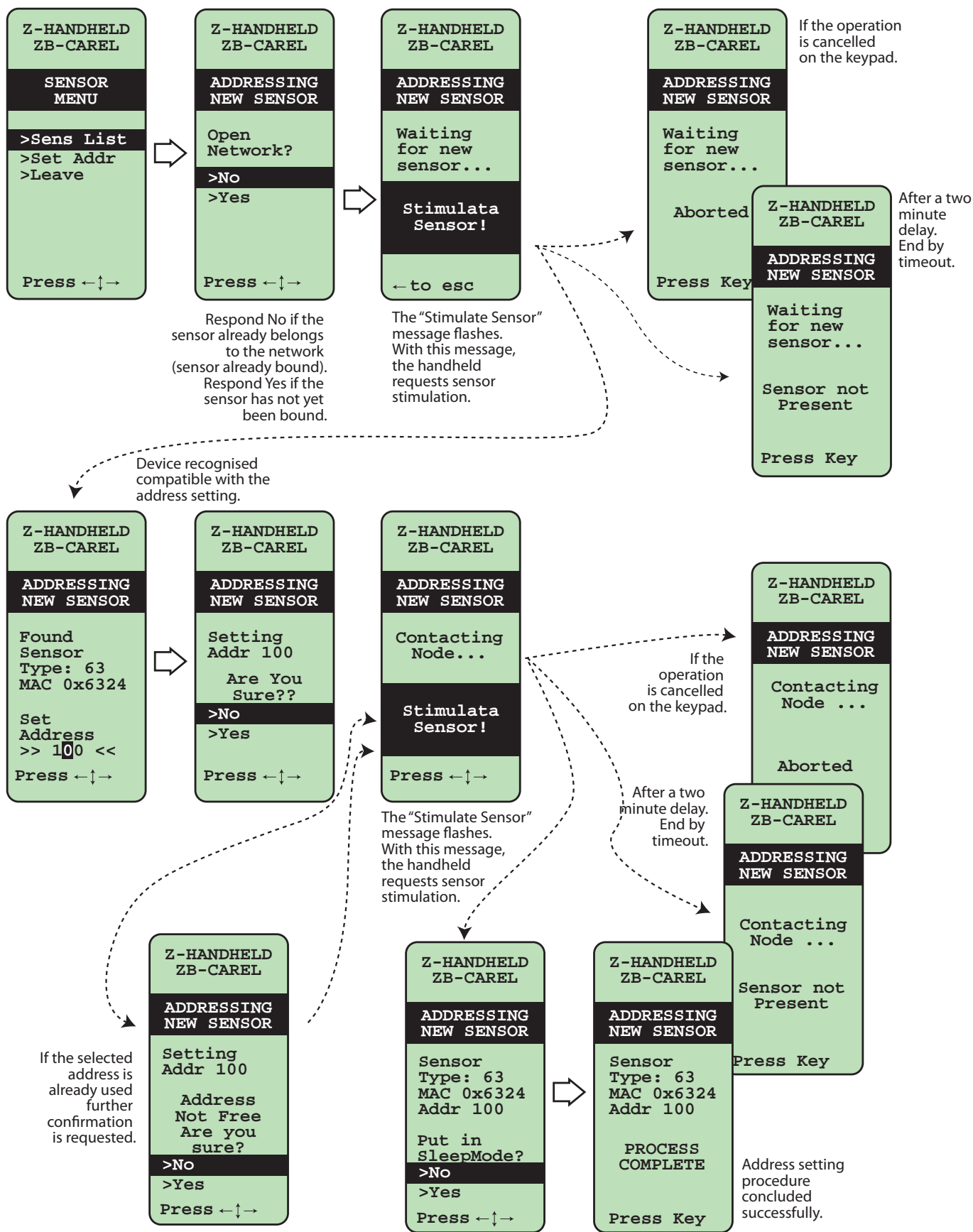

Fig. 13.q

13.18 Unbind Sensor

This menu is used to unbind an individual sensor.

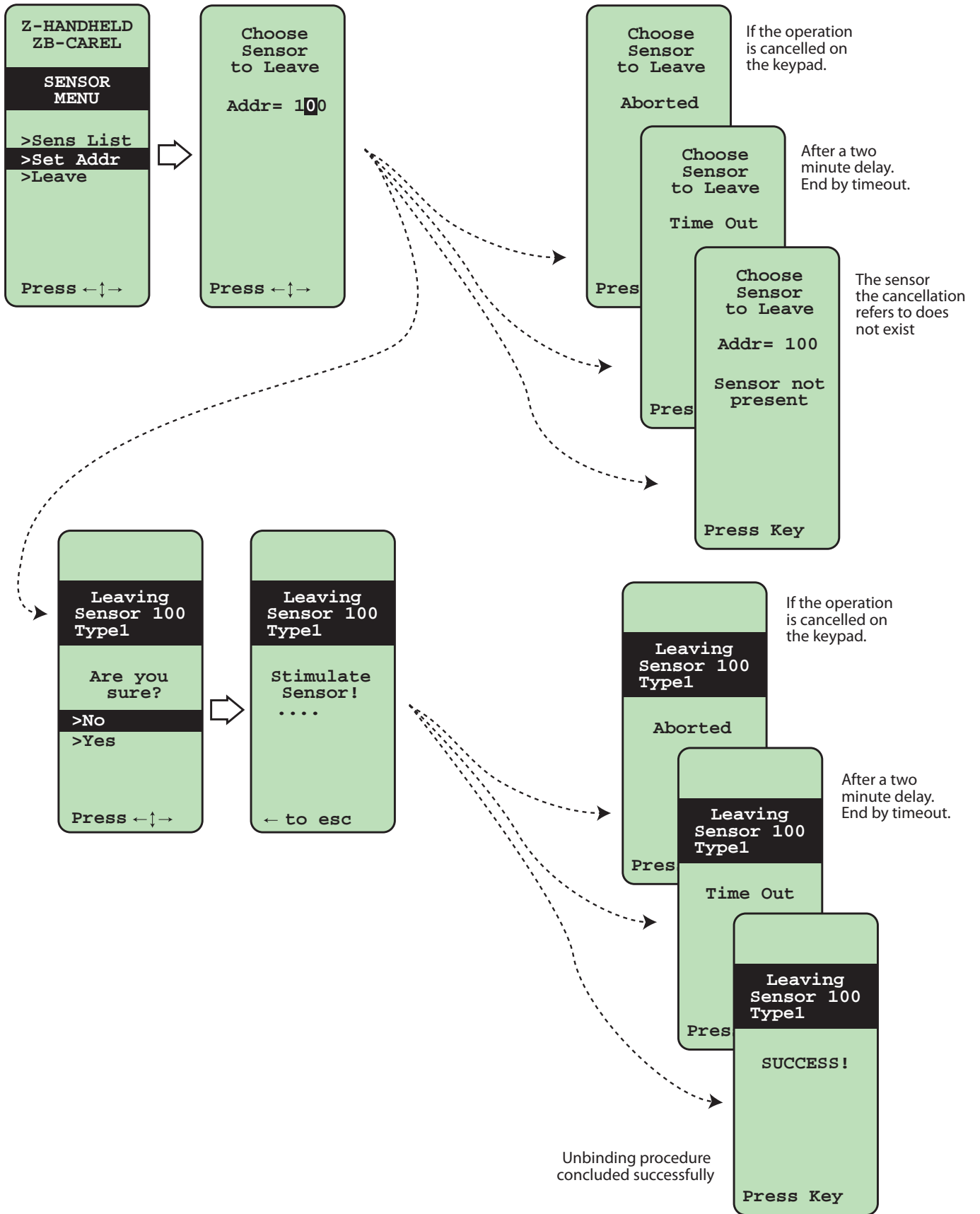

Fig. 13.r

13.19 Start screen

When first starting the device (inserting the batteries), the ZigBee™ handheld wireless signal level meter shows the following screens in rapid succession:

- Completely black screen
- Bootloader activation screen
- Start-up animation (grid)
- Screen showing component check procedure and version number

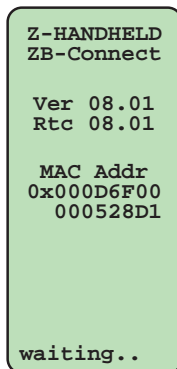

Fig. 13.s

13.20 ZigBee™ handheld signal meter shutdown

The handheld wireless signal level meter automatically goes into low power mode after four minutes of inactivity to extend battery life.

Low power mode can be activated manually by pressing the "Off" button.

In low power mode, pressing any button returns the device to the previous status.

Note: during the Ping Test, the Off button only switches the device to low power mode for a few seconds.

Note: If the handheld wireless signal level meter is not used for an extended period (a few weeks) the batteries should be removed.

Battery Life

The estimated battery life is 26 hours of continuous operation of the device.

(power consumption 12J/minute, battery power 19000J, --> 19000/12 = 1580 min = 26.3 hours)

13.21 Notes on operation

The ZigBee handheld wireless signal level meter has been designed for use when installing a new network of devices.

It identifies the number of Routers and Access Points that are accessible from the position where the ping test is performed.

The ping test also provides information on the strength of the wireless signal on the Routers and Access Points in the vicinity, highlighting whether the connections are good or have a low signal.

The installation guidelines require each Router to be within radio range of at least two other Routers. The same applies to the sensors; indeed, each sensor should be connected with a good signal to at least two different Router devices (or Access Points).

Where installation restrictions limit the optimum positioning of the Router and sensors, the handheld wireless signal level meter can help identify the best position for the additional Routers that must be installed in order to cover the areas not reached by the wireless signal.

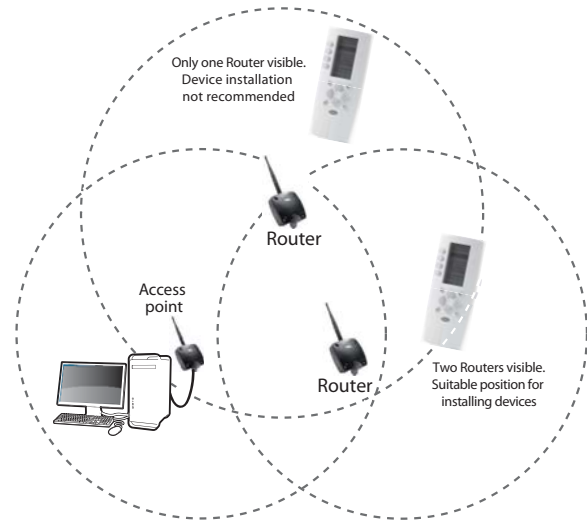

Fig. 13.t

13.22 ZigBee™ handheld signal meter electrical specifications

POWER SUPPLY:	3 x 1.5V batteries, "AAA" size
RADIO CHARACTERISTICS:	2405 MHz - 2480 MHz
Rated transmission power	0 dBm
Compliant with standard	IEEE 802.15.4
EmberZNet stack	3.3.x
INDEX OF PROTECTION:	IP40
Code	WS01L01M00 rTM SE handheld

Tab. 12.a

13.23 Physical dimensions

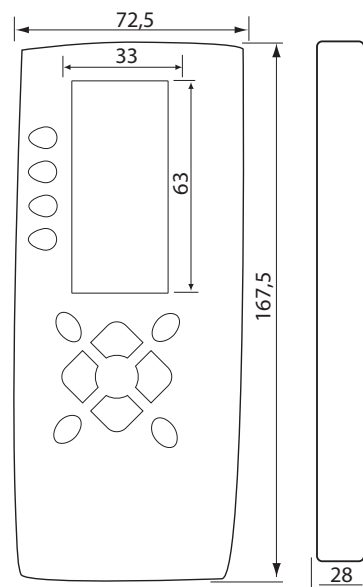

Fig. 13.u

Rules for disposing of the battery

Do not dispose of the product as municipal waste; it must be disposed of through specialist waste disposal centres.

The product contains a battery that must be removed and separated from the rest of the product.

Improper use or incorrect disposal of the product may have negative effects on human health and on the environment.

The public or private waste collection systems defined by local legislation must be used for disposal.

In the event of illegal disposal of electrical and electronic waste, the penalties are specified by local waste disposal legislation.

14. ROUTER-SNIFFER

14.1 Router-Sniffer

The sniffer for ZigBee™ networks is a hardware device connected to the USB port of a personal computer running a special program (Z-Config, downloadable from KSA) that analyses Carel proprietary ZigBee™ networks and identifies which devices are able to communicate with one another, measuring the quality of the wireless signal. Z-Config in fact displays a graph of wireless connection quality between the various Router nodes in the network, displaying which sensors these receive the wireless signal from.

14.2 Technical specifications:

Power supply:	from USB port on the PC
Radio characteristics	2405 MHz - 2480 MHz
Modulation	DSSS
Rated transmission power	0 dBm
Standard	IEEE 802.15.4 compliant
EmberZNet stack	3.4.1
Stack Profile	0
Profile	Proprietary ID
Encryption key	Proprietary
Index of protection	IP55
Code	WS01M02M20 rTM SE Router-Sniffer (Modbus® network configurator) rTM SE Router-Sniffer (Modbus® Network Configurator)

Tab. 14.a

14.3 Layout

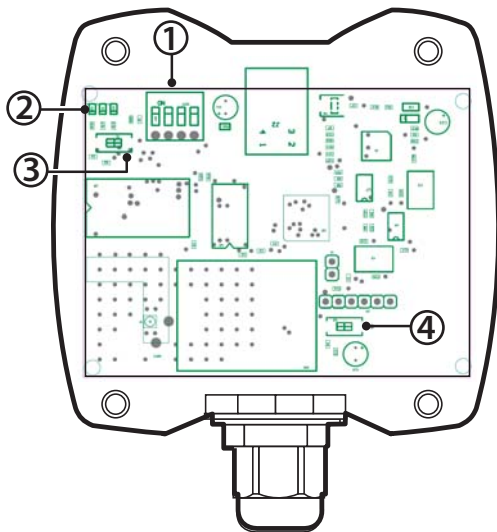

Tab. 14.a

1. Dipswitches,
2. LEDs;
3. Button;
4. Reset button

The button and dipswitches have no functions.

14.4 LED meanings

Router-Sniffer unbound: all the LEDs flash together

Router-Sniffer associated: only LED L2 flashes

On power-up, LEDs L1, L2, L3 on the Router-Sniffer come on for around three seconds then flash quickly for around another three seconds.

Physical dimensions

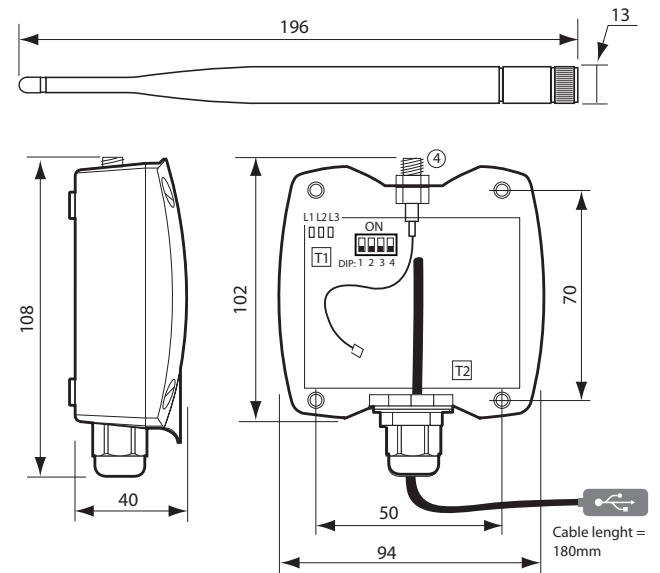

Tab. 14.b

Note: All the measurements are in mm.

15. Z-CONFIG PROGRAM

System requirements

Z-Config runs on a Personal Computer with the Microsoft Windows 98, 2000, XP or XP SP2 operating system. The program's limited use of memory resources (hard disk-RAM) means it can be installed and run on any recent PC. Installation of the program requires installation of the DotNetFramework version 2.0

Starting the program

When starting Z-Config, the following screen is displayed:

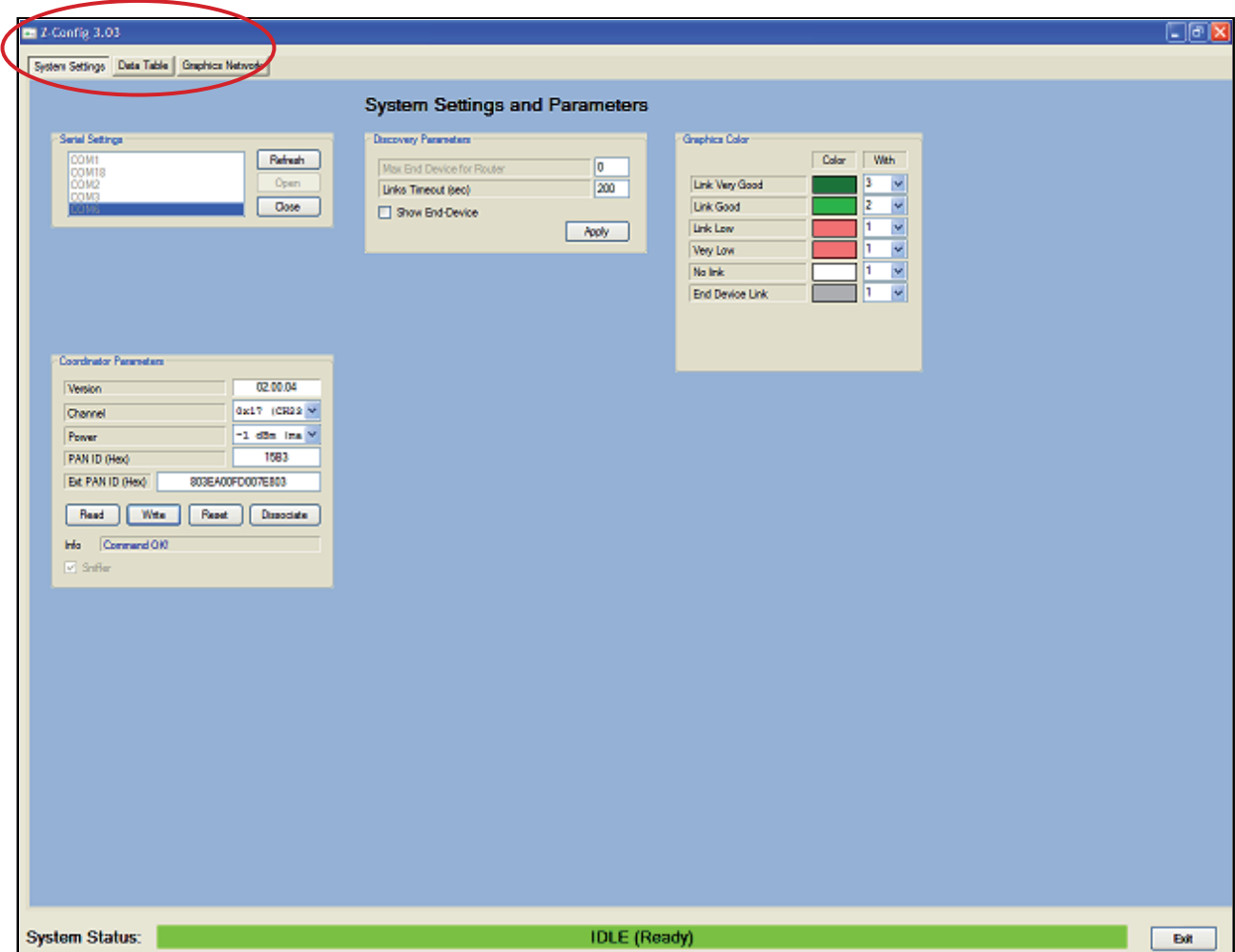

Fig. 15.a

Main program windows

The program is divided into three main windows, selected using the buttons at the top left of the program window



Fig. 15.b

System Settings:

Window containing the settings for the serial communication port, network settings and graphics settings under the "Graphics Network" window.

Data Table:

This window shows the summary table of past and current wireless communication between the Router-Sniffer and the devices in the network this is connected to.

Graphics Network:

Window showing a graph of connection levels between the devices in the network.

“System Settings” window

This window features several frames:

Opens the serial port for communication with the Router-Sniffer. The port corresponding to the Router-Sniffer device must be selected. If there are several ports and it's not clear which one the Router-Sniffer is connected to, unplug the device from the Personal Computer; then select the Refresh button, reconnect the Router-Sniffer and then select Refresh again. The newly connected Router-Sniffer will be displayed in the list and will be easy to identify.

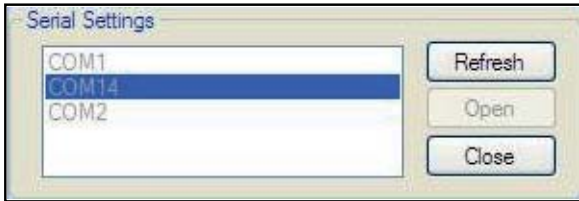

Fig. 15.c

Network Parameters

The network parameters consist of the Transmission channel (16 possible values, from 11 to 26), the network PanID (network address) and the extended PanID.

The network parameters must be identical to the network being monitored. To identify the parameters of the desired network, check the data in the installation file or on the supervisor.

When opening the serial connection (see the serial connection box), selecting the “Read” button in the “Network Parameters” box reads the network parameters for the Router-Sniffer connected to Z-Config.

If the network parameters are not available (new Router-Sniffer or unbound from the network) the default channel is 0x0B (CH11), the default PanID is 0xFFFF and the default extended PanID is null.

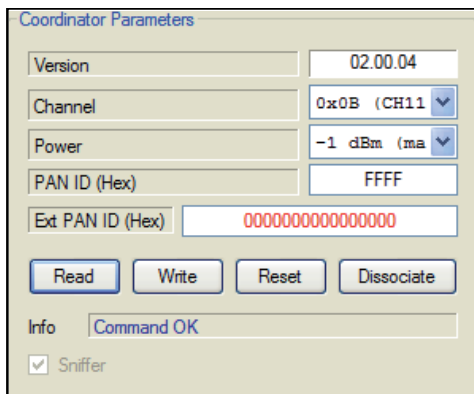

Fig. 15.d

Set the desired network parameters (channel and PanID), selecting “Write” runs the command and connects the Router-Sniffer to the desired network. Only set the channel and PanID; the extended PanID must not be written, as it's read by the network.

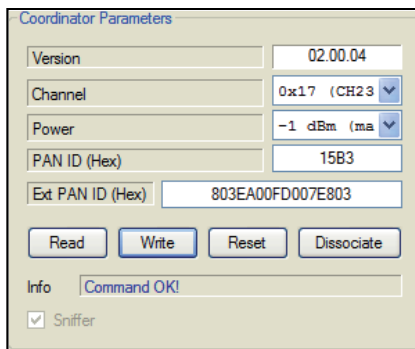

Fig. 15.e

If the channel and PanID are set incorrectly and do not correspond to any network in the vicinity of the Router-Sniffer, the extended PanID is not detected and remains null.

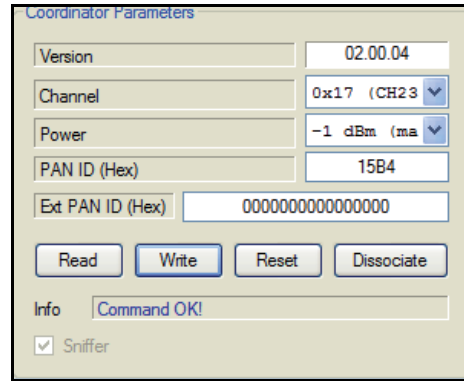

Fig. 15.f

The transmission power of the Router-Sniffer can be set (using the corresponding tag); to enable the value, once again select “Write”. Changing the power has no major significance; indeed it's recommended to leave the maximum value (-1 dB).

Selecting “Reset” resets the Router-Sniffer.

Selecting “Disassociate” unbinds the Router-Sniffer from the current network and consequently initialises the network parameters.

Note: if the network binding or unbinding operations are successful, an OK message is shown in the info field.

Important: after having set the network parameters (selecting “Write”), in order to properly initialise the program tables, close and open Z-Config again.

Graphics Colour

This box is used to set the appearance of the connecting lines between the nodes in the “Graphics Network” window.

The thickness and colour of the lines can be set based on the band the connection belongs to.

The thicknesses of the lines range from 1 (thin line) to 5 (thick line).

The colours of the lines can be selected from a standard colour palette.

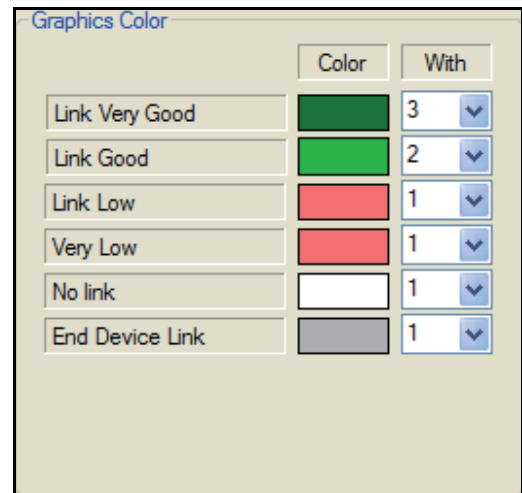

Fig. 15.g

“Data Table” window

The “Data Table” window shows a table of the devices in the network. Initially this table only shows the “Router Sniffer” device, simply called the “Sniffer”. Selecting “Start Discovery” activates discovery of the nodes in the network. The process continues indefinitely until selecting “Stop Discovery”. The node currently being queried is highlighted in the table.

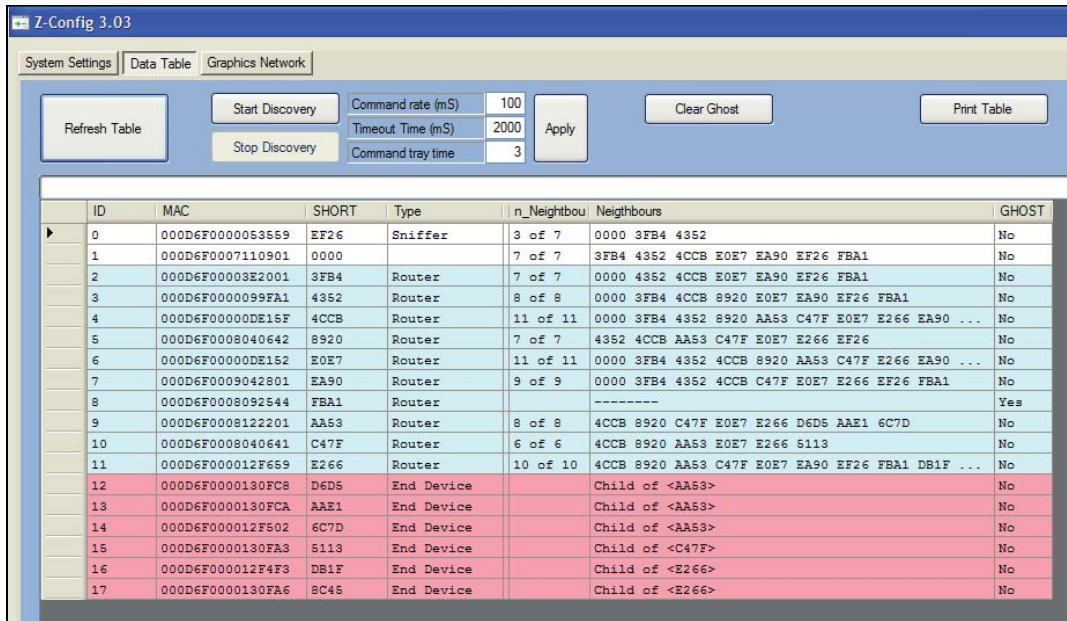

Fig. 15.h

Backgrounds:

All ZigBee™ Routers send a wireless message at regular intervals (around every 16 seconds). This message is called “Neighbour Exchange”, it’s essentially a presence notification message. All Routers within radio range receive the messages and use them to internally create a table called the “Neighbours Table”. This table keeps track of all the Routers that a certain Router can see in the immediate vicinity, together with the quality of the wireless signal. The table is then used to define the routing of the wireless messages, and consequently is fundamental in managing wireless traffic. During the “Discovery” process, Z-Config extracts the data from the Neighbour Tables of all the Routers and Access Points in the network. The “Discovery” processes start by extracting the Neighbour Table of the Router-Sniffer. Each Router listed in the Router-Sniffer Neighbour Table creates a new row in the “Data Table”. Each Router in the table is then queried for its Neighbour Table data. This process continues until all the Routers in the network have been queried. At the end the process starts again cyclically.

Meaning of the columns:

- ID:** progressive number
- MAC ADDRESS:** MAC ADDRESS of the node, this represents the unique address of the device (8 bytes). This address is resident in the device from when it is manufactured, and cannot be overwritten or deleted for the entire life of the device. The address is represented in hexadecimal notation.
- SHORT:** Device network address. (This address may change during the life of the device). The address is used for routing the wireless messages from and to any other node of the network. The address is represented in hexadecimal notation.
- Type:** Type of device (Sniffer, Access Point, Router, Sensor)
- N_Neighbours:** Number of Routers that the device can see in radio range.
- Neighbours:** Network addresses of nearby devices. These addresses are represented in hexadecimal notation. The data are used to create the graphic links in the “Graphics Network” window.
- GHOST:** This column indicates whether the node is not working and consequently has been excluded. “No” indicates that the device is working correctly.

Meaning of the parameters:

- Command rate [mS]:**
Interval between receiving a response and sending the subsequent query (min 100mS).
- Timeout Time [mS]:**
Interval to wait for a response, after which a further attempt is performed.
- Command Retry:**
Number of consecutive transmission attempts without a response, after which the node is declared as being a Ghost; from that moment on the node marked as being a Ghost is no longer queried.

Meaning of the buttons:

- Refresh Table:**
Refreshes the table of nodes
- Start Discovery:**
Starts the network discovery process, querying the “Neighbour Table” on the Router-Sniffer and then on all the Routers in the network. The network discovery process continues indefinitely, until the program is closed or “Stop Discovery” is selected.
- Stop Discovery:**
Ends the network discovery process.
- Apply:**
Applies the changes made to the operating parameters
- Clear Ghost:**
Deletes all the “Ghost” labels detected during the network discovery process.
- Clear Table**
Deletes the entire table
- Print Table**
Menu of print functions

Notes on operation:

The information summarised in the “Data Table” is the only data that Z-Config can extract from the network nodes. All “application layer” information, such as logical number, operating parameters or other data cannot be extracted directly by Z-Config.

The network Discovery process involves numerous wireless messages being sent between the Router-Sniffer and all the nodes in the network. This generates significant wireless traffic that may interfere with the normal messages being sent over the network. Consequently, the Discovery process should not be left running indefinitely but rather only for the time needed to analyse the network.

When first running the Discovery process or after resetting the Router-Sniffer, some of the MAC addresses relating to Routers discovered in the network may be null (0000000000000000); To resolve this problem, wait until all the Routers have been discovered, stop the process, wait a few seconds, select “Clear Table” and then start the Discovery process again.

Before first running the network Discovery process, and when the layout of the network is modified (adding or moving a Router), for more precise information all the Router nodes in the network should be reset.

“Graphics Network” window

This window represents the data from the previous table in graphic form. The information helps provide a good idea of the physical structure of the network.

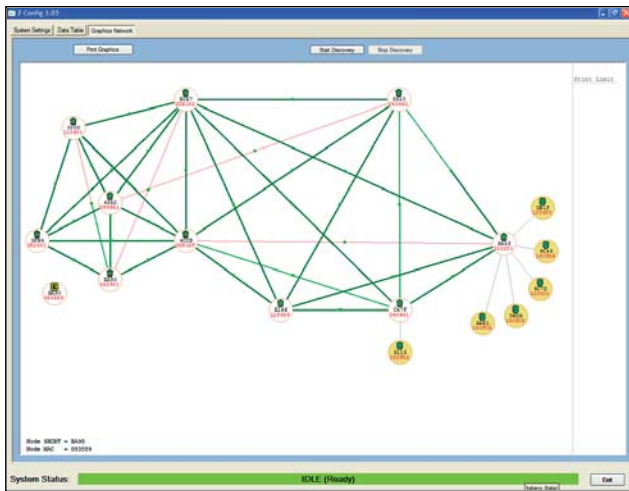

Fig. 15.i

Key to the graphic symbols

	<p>Graphic element representing the Router-Sniffer:the network address (SHORT) is in black,the MAC address is in red (last eight figures only)All these numbers are in hexadecimal format.</p>
	<p>Graphic element representing a Router:the network address (SHORT) is in black,the MAC address is in red (last six figures only)All these numbers are in hexadecimal format.Important: If SHORT=0000 the node is the coordinator (Gateway).</p>
	<p>Graphic element representing an End-Device:the network address (SHORT) is in black,the MAC address is in red (last six figures only)All these numbers are in hexadecimal format.</p>

Tab. 15.a

Links between Routers

The connecting lines between the Router nodes indicate the quality of the respective wireless connections (LQI). The thickness and colour of the lines are set in the “System Settings” window. In the centre of the link line is a green dot that divides the line into two equal segments. The two segments of the link line represent the two mutual quality levels; the segment connected to the node represents the quality with which the node receives the messages from the other node. Often the links are asymmetrical, meaning the link line has two different colours (and/or thicknesses). This occurs if one of the two nodes sees the other with a stronger or weaker signal. There may be various reasons for this, for example if one of the two nodes features power amplifiers or an antenna with better gain.

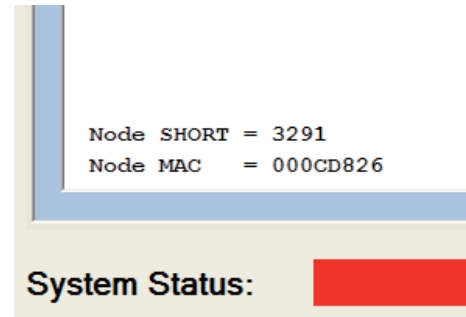

Fig. 15.j

When selecting an element in the network, the bottom left corner displays the SHORT data, with reference to the device’s “Data Table” and MAC address.

Links between Routers and Sensors

For sensors the connecting line does not provide information on the quality of the wireless connection, but rather simply indicates which Router is the device’s “parent”.

Meaning of the buttons:

- Print Graphics:
Menu of print functions
- New Region:
Button used to create a rectangle in the graphics window with customisable name and size.
- Remove Region:
Button used to delete a rectangle in the graphics window.
- Start Discovery:
Same function as the same-name button in the “Data Table” window.
- Stop Discovery:
Same function as the same-name button in the “Data Table” window.

Identification of nodes in the network

Nodes can be identified using their MAC address printed on the device label. This is in fact the only unique value amongst the data available in the Z-Config program. Alternatively, the device can only be identified indirectly (for example, switching a Router off and then seeing which of the nodes in table is marked as a GHOST after some time).

Device layout:

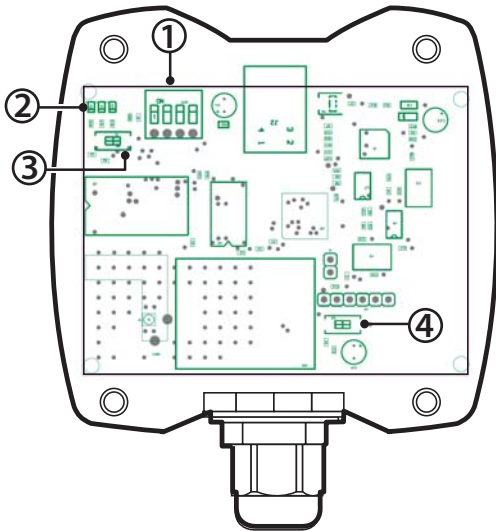

Fig. 15.k

The button and dipperswitches on the Router-Sniffer have no function.

LED meanings:

Router-Sniffer unbound: all the LEDs flash together
 Router-Sniffer associated: only the centre LED flashes
 On power-up, the LEDs on the Router-Sniffer come on for around three seconds then flash quickly for around another three seconds.

Purpose of Z-Config

Z-Config is essentially used to analyse the reciprocal positions of the Routers in a certain ZigBee network.
 It can be used to identify any critical points in the network.

Installation example:

The following figure represents a network made up of 10 Routers, the Router-Sniffer and two Sensors.
 As can be seen, the network is divided into two subnetworks.
 The two subnetworks are connected by just one good quality link (the blue line that joins node 2560 to node 0730).
 All the other links are poor quality (they're in fact illustrated by thin yellow lines).
 This situation represents a network with possible critical areas.
 Indeed, if there are obstacles in the link between node 2560 and node 0730, the two networks may be temporarily isolated from one another.

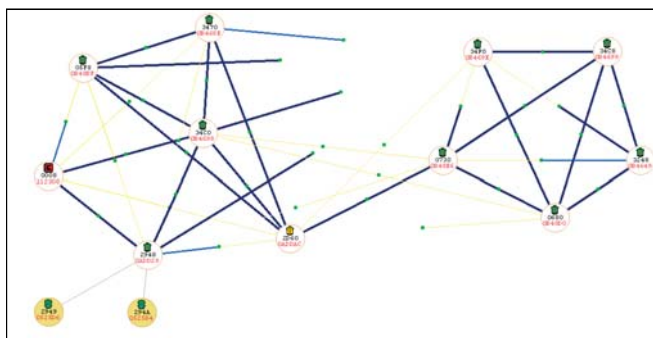

Fig. 15.l

Situations of this type should be corrected and, where possible, further Routers added in order to increase the number of connections between any subnetworks.

An alternative to installing additional Routers is to move the existing ones to better positions.

The following figure represents the same network in which an additional Router has been installed in a strategic position.

As can be seen, the two subnetworks are connected by a further good quality link (the blue line that joins the new node 3258 to node 0680).

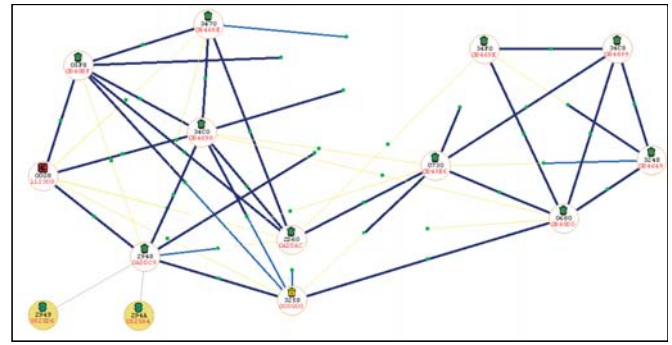

Fig. 15.m

Identification of network parameters for ModBus networks

Modbus network parameters can be read by querying the network Access Point.

The network channel is available by reading InputRegister[IR_03] on the Access Point.

The network PanID is available by reading InputRegister[IR_04] on the Access Point.

The network extended PanID is available by reading InputStatus[17],[18],[19],[20] on the Access Point.

Important:

Before running network Discovery using Z-Config, all the Routers in the Modbus network should be reset, then wait around one minute.
 This may be done simply by sending the special reset command to all the Routers.

After having completed this operation, the Access Point also needs to be reset using the special command. This operation aligns the wireless routes and provides an updated situation of the system (it updates the links between the Access Point, Routers and sensors).

15.5 Layout examples

Installation examples:

- Application example involving 15 Sensors with one Access Point and Router-Bridge

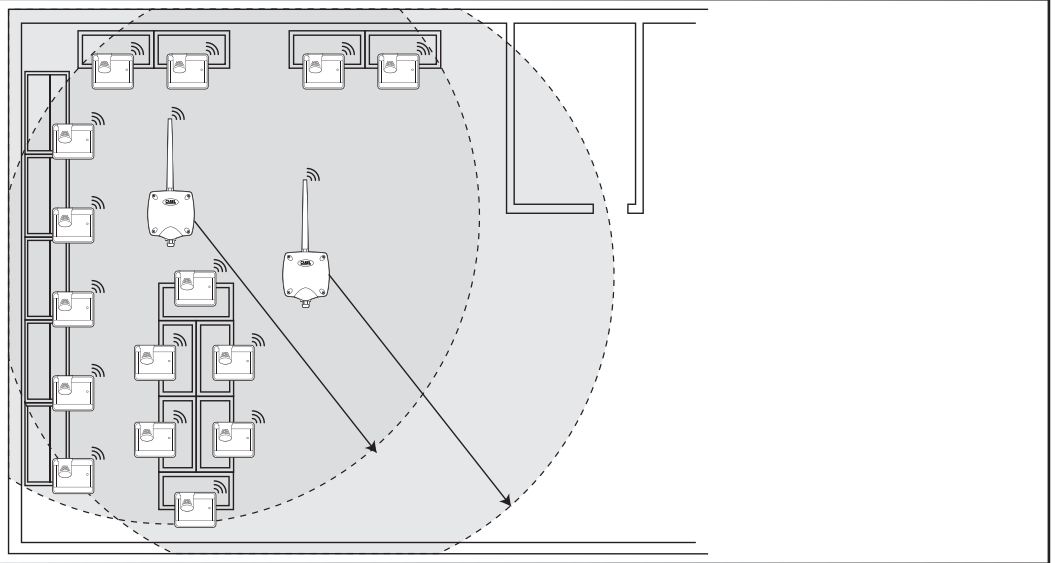

Fig. 15.n

- Application example involving 30 Sensors with one Access Point and 2 Router-Bridges

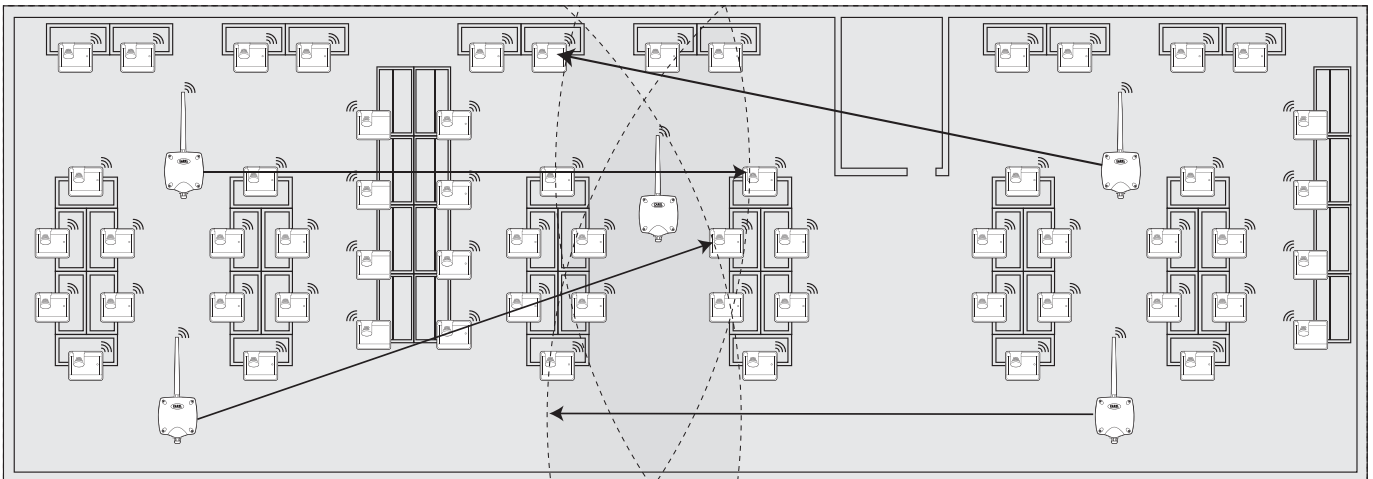

Fig. 15.o

- Application example involving 30 Sensors with one Access Point and 2 Router-Bridges

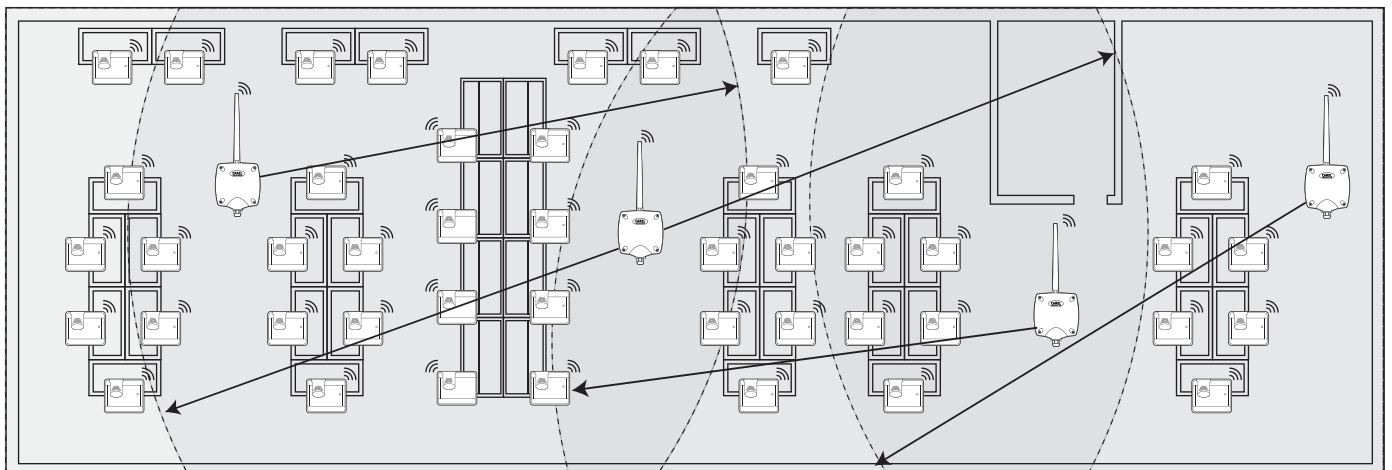

Fig. 15.p

- Application example involving 45 Sensors with one Access Point and 3 Router-Bridges

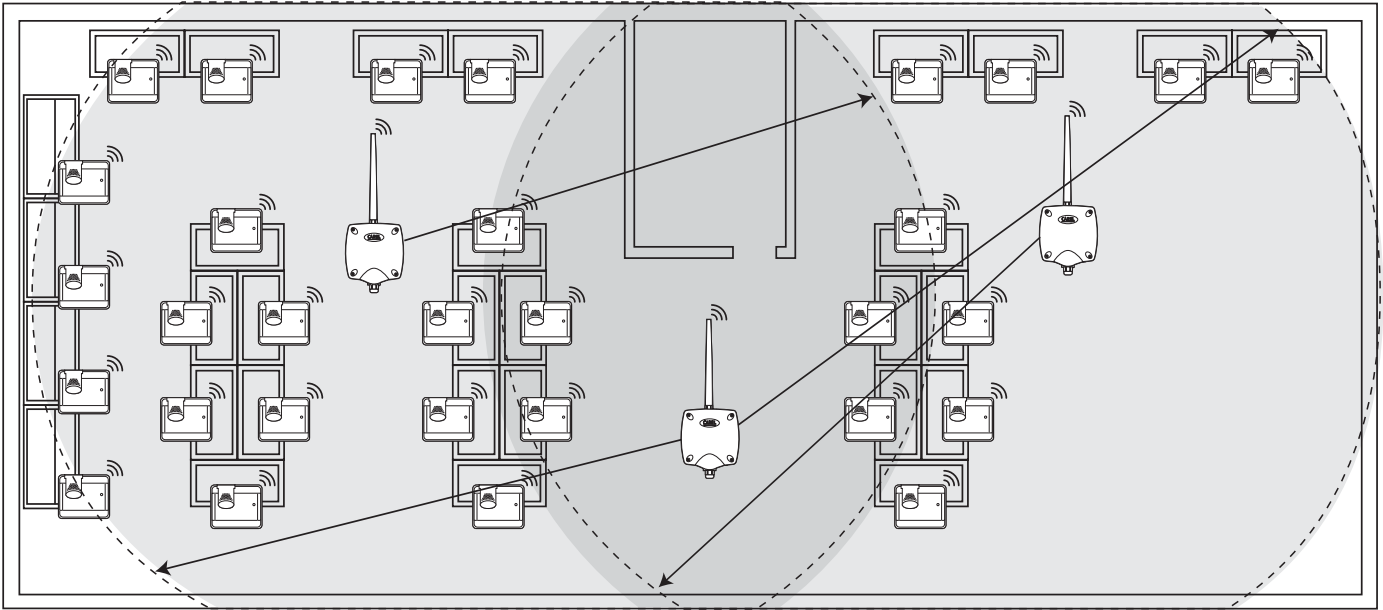

Fig. 15.q

16. DIPSWITCH-ID CROSS-REFERENCE TABLE FOR SENSORS

16.1 Dipswitch-ID cross-reference table for sensors

	Dipswitch							
	1	2	3	4	5	6	7	8
16	0	0	0	0	1	0	0	0
17	1	0	0	0	1	0	0	0
18	0	1	0	0	1	0	0	0
19	1	1	0	0	1	0	0	0
20	0	0	1	0	1	0	0	0
21	1	0	1	0	1	0	0	0
22	0	1	1	0	1	0	0	0
23	1	1	1	0	1	0	0	0
24	0	0	0	1	1	0	0	0
25	1	0	0	1	1	0	0	0
26	0	1	0	1	1	0	0	0
27	1	1	0	1	1	0	0	0
28	0	0	1	1	1	0	0	0
29	1	0	1	1	1	0	0	0
30	0	1	1	1	1	0	0	0
31	1	1	1	1	1	0	0	0
32	0	0	0	0	0	1	0	0
33	1	0	0	0	0	1	0	0
34	0	1	0	0	0	1	0	0
35	1	1	0	0	0	1	0	0
36	0	0	1	0	0	1	0	0
37	1	0	1	0	0	1	0	0
38	0	1	1	0	0	1	0	0
39	1	1	1	0	0	1	0	0
40	0	0	0	1	0	1	0	0
41	1	0	0	1	0	1	0	0
42	0	1	0	1	0	1	0	0
43	1	1	0	1	0	1	0	0
44	0	0	1	1	0	1	0	0
45	1	0	1	1	0	1	0	0
46	0	1	1	1	0	1	0	0
47	1	1	1	1	0	1	0	0
48	0	0	0	0	1	1	0	0
49	1	0	0	0	1	1	0	0
50	0	1	0	0	1	1	0	0
51	1	1	0	0	1	1	0	0
52	0	0	1	0	1	1	0	0
53	1	0	1	0	1	1	0	0
54	0	1	1	0	1	1	0	0
55	1	1	1	0	1	1	0	0
56	0	0	0	1	1	1	0	0
57	1	0	0	1	1	1	0	0
58	0	1	0	1	1	1	0	0
59	1	1	0	1	1	1	0	0
60	0	0	1	1	1	1	0	0

	Dipswitch							
	1	2	3	4	5	6	7	8
61	1	0	1	1	1	1	0	0
62	0	1	1	1	1	1	0	0
63	1	1	1	1	1	1	0	0
64	0	0	0	0	0	0	1	0
65	1	0	0	0	0	0	1	0
66	0	1	0	0	0	0	1	0
67	1	1	0	0	0	0	1	0
68	0	0	1	0	0	0	1	0
69	1	0	1	0	0	0	1	0
70	0	1	1	0	0	0	1	0
71	1	1	1	0	0	0	1	0
72	0	0	0	1	0	0	1	0
73	1	0	0	1	0	0	1	0
74	0	1	0	1	0	0	1	0
75	1	1	0	1	0	0	1	0
76	0	0	1	1	0	0	1	0
77	1	0	1	1	0	0	1	0
78	0	1	1	1	0	0	1	0
79	1	1	1	1	0	0	1	0
80	0	0	0	0	1	0	1	0
81	1	0	0	0	1	0	1	0
82	0	1	0	0	1	0	1	0
83	1	1	0	0	1	0	1	0
84	0	0	1	0	1	0	1	0
85	1	0	1	0	1	0	1	0
86	0	1	1	0	1	0	1	0
87	1	1	1	0	1	0	1	0
88	0	0	0	1	1	0	1	0
89	1	0	0	1	1	0	1	0
90	0	1	0	1	1	0	1	0
91	1	1	0	1	1	0	1	0
92	0	0	1	1	1	0	1	0
93	1	0	1	1	1	0	1	0
94	0	1	1	1	1	0	1	0
95	1	1	1	1	1	0	1	0
96	0	0	0	0	0	1	1	0
97	1	0	0	0	0	1	1	0
98	0	1	0	0	0	1	1	0
99	1	1	0	0	0	1	1	0
100	0	0	1	0	0	1	1	0
101	1	0	1	0	0	1	1	0
102	0	1	1	0	0	1	1	0
103	1	1	1	0	0	1	1	0
104	0	0	0	1	0	1	1	0
105	1	0	0	1	0	1	1	0

	Dipswitch							
	1	2	3	4	5	6	7	8
106	0	1	0	1	0	1	1	0
107	1	1	0	1	0	1	1	0
108	0	0	1	1	0	1	1	0
109	1	0	1	1	0	1	1	0
110	0	1	1	1	0	1	1	0
111	1	1	1	1	0	1	1	0
112	0	0	0	0	1	1	1	0
113	1	0	0	0	1	1	1	0
114	0	1	0	0	1	1	1	0
115	1	1	0	0	1	1	1	0
116	0	0	1	0	1	1	1	0
117	1	0	1	0	1	1	1	0
118	0	1	1	0	1	1	1	0
119	1	1	1	0	1	1	1	0
120	0	0	0	1	1	1	1	0
121	1	0	0	1	1	1	1	0
122	0	1	0	1	1	1	1	0
123	1	1	0	1	1	1	1	0
124	0	0	1	1	1	1	1	0
125	1	0	1	1	1	1	1	0
126	0	1	1	1	1	1	1	0

Tab. 16.a

CAREL

CAREL INDUSTRIES HeadQuarters

Via dell'Industria, 11 - 35020 Brugine - Padova (Italy)

Tel. (+39) 049.9716611 - Fax (+39) 049.9716600

e-mail: carel@carel.com - www.carel.com

Agenzia / Agency: